

**45RM1 SCANNER  
MODELS 1001, 1003  
45RM2 SCANNER  
MODELS 1000, 1001  
(including EX Models)  
Background Gain Control Flame Scanners**



See Table 1



Year 2000 Compliant in accordance with BSI document DISC PD2000-I:1998



**This bulletin is directed to the licensed boiler service technicians and professional combustion engineers who are experienced in the installation and operation of Fireye flame safeguard controls. Persons not experienced with Fireye flame safety products should contact the nearest Fireye representative, or a qualified service group for assistance. IMPROPER INSTALLATION OF THESE PRODUCTS MAY BE HAZARDOUS TO LIFE AND PROPERTY.**

## DESCRIPTION

Fireye type 45RM1 and 45RM2 Scanners are self-checking, flame sensing devices. They consist of a lens, photodetector and a solid-state, frequency tuned circuit contained in a die cast aluminum housing. When powered by a compatible, self-checking Fireye flame safeguard control, the scanners detect the presence or absence of flames having certain characteristics. Flames monitored by the type 45RM1 and 45RM2 scanners may be those of pulverized coal, oil, or a combination of fuels. Type 45RM2 scanners also respond to natural gas flames and flames of other sources of methane, propane, butane, and other gases. A dimensional drawing of the surface mounted scanners is shown in Figure 1. For detailed information on Fireye fiber-optic scanners see Bulletin CU-21.

## APPLICATION

When properly sighted on a flame's primary combustion (high energy) zone, type 45RM1 and 45RM2 scanners discriminate between the targeted flame and adjacent flame envelopes, background radiation, and flames associated with a reservoir of fuel. These unique design features enable the scanners to be applied, in conjunction with a compatible Fireye flame safeguard control, on single and multiple burner apparatus including power, industrial process and electric utility furnaces and boilers.

*NOTE: The response of the scanners is dependent on burner configuration as well as the turbulence and spectral characteristics of the flames. Application assistance is available on request.*

## OPERATION

The 45RM1 and 45RM2 Scanners utilize the relationship of the red and infrared radiation bands of modulation frequencies occurring within a flame. Figure 2 shows the amplitude of the high frequency band in relation to the low. High frequency (200-600 Hz) amplitudes are at maximum in the



ignition zone or primary combustion zone while low frequency (below 100 Hz down to steady-state) amplitudes are at their minimum in the same region.

Through a narrow sight angle, radiation from the primary combustion zone is focused on a photodetector in the scanner. Radiation signal levels from the photodetector are passed to a background gain control (BGC) broadband amplifier (Figure 3) which produces an output signal that is a direct function of the higher and an inverse function of the lower frequency components of the sensed radiation. The result is an accentuated (dashed line, Figure 2) high frequency component, the prime indicator of flame presence and intensity. This accentuation is the key to the effectiveness of the type 45RM1 and 45RM2 scanners to discriminate over a very broad dynamic range without field adjustment of the electronics.

From the BGC amplifier the signal then passes through an operator adjustable gain-setting potentiometer into a bandpass amplifier (see Figure 3), which discards the low-frequency signal and amplifies the high-frequency component. It is this signal, indicating the presence and intensity of flame in the primary combustion zone, which then goes to the signal detector/pulse generator and the threshold detector. The threshold detector controls the output of the signal detector/pulse generator, disabling its output until the average amplitude from the bandpass amplifier reaches a pre-set minimum level. Once the output is enabled, it is allowed to continue until a second, lower limit is reached.

The threshold detector thus prevents spurious signals from giving ambiguous flame-status information. The frequency of pulses from the signal detector/pulse generator is proportional to the signal intensity from the bandpass amplifier and is similar in amplitude and duration to the output of a Fireeye ultra-violet detector tube. Upon flame failure the pulses stop entirely. The output signal is compatible with the Fireeye flame safeguard controls listed in Figures 15 through 21.

Also included in the scanner is an electromagnetic shutter that permits a self-checking circuit within an associated control to verify that the scanner and signal circuits are producing valid flame presence or absence information. During the shutter closed period the detector's optical path is blocked from flame radiation. While the shutter is open, flame presence or absence is detected. The resultant scanner output, while flame is detected, is a continuous, periodically interrupted, pulsed flame signal which is a prerequisite for energizing the associated Fireeye control's Flame Relay.

FIGURE 1 DIMENSIONS

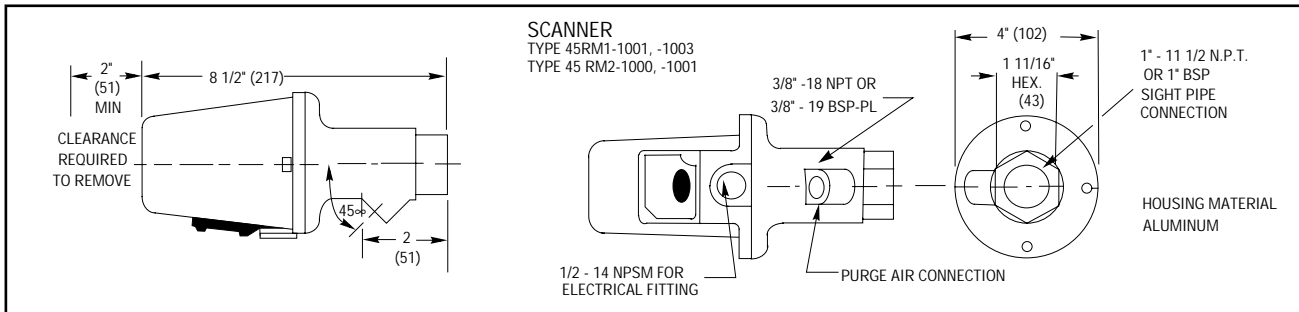
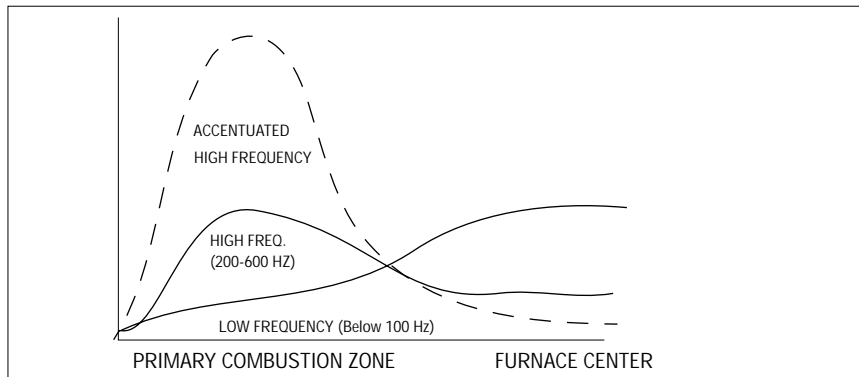
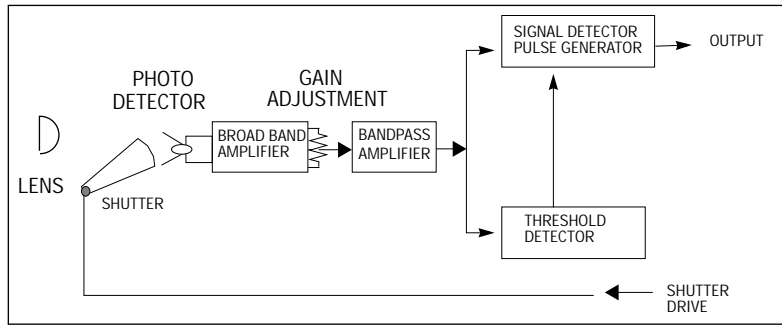

FIGURE 2 RELATIVE POSITION OF SCANNER TARGET ON FLAME



**FIGURE 3** INTERNAL BLOCK DIAGRAM



## SPECIFICATIONS

### MOUNTING

Surface Mounted Models are provided with 1" female thread mounting. Either US NPT or British BSP according to model (See Table 1).

Heat Insulating Nipple 1": 11<sup>1</sup>/<sub>2</sub> NPT or 1" BSP provided (refer to Figure 11K).

### HOUSING, INCLUDING MOUNTING FLANGE

**Material:** Die cast aluminum

**Design:** Mounting Flange with Purge Air fitting to be permanently installed, carries two 1/4-20 screws which may be loosened for quick removal of the scanner electronics housing, such as for lens cleaning.

**Weight:** 2.4 Lbs. (1.1 kg)

### ELECTRICAL

**Power Requirement:** 5 VA AC from associated control

**Frequency:** 50/60 Hz

**Connection:** 1/2 in. 14 NPSM tapping

**Sensitivity Adjustment:** Turn the potentiometer, located under the screw on the rear of the scanner housing, with a screwdriver. Maximum sensitivity is clockwise.

### TEMPERATURE RANGE

**Maximum operating:** 150° F (65° C)

**Minimum operating:** -40° F (-40° C)

**Humidity:** 0 to 95% R.H. noncondensing

### PURGE AIR

**Source:** Clean ambient

**Volume Required:** 4 SCFM (113 L/min) at 3/8 inch threaded housing inlet or 4 SCFM at 1 inch wye fitting in scanner sight pipe. Temperatures near the upper limit of the scanner operating range and/or use with dirty fuels may require up to 15 SCFM (425 L/min).

**Table 1:**

### AGENCY APPROVALS:

MODELS	FM	CSA	DIN	APAVE	DVGW	THREADS
45RM1-1001	✓	✓				NPT
45RM1-1003	✓		✓		✓	BSP
45RM2-1000	✓	✓		✓		NPT
45RM2-1001	✓		✓		✓	BSP

Specifications subject to change without notice.

## Optional Mounting Configurations for Hazardous Areas

FIGURE 4 45RM1, 45RM2 SCANNER IN NEC/NEMA HAZARDOUS AREA HOUSING

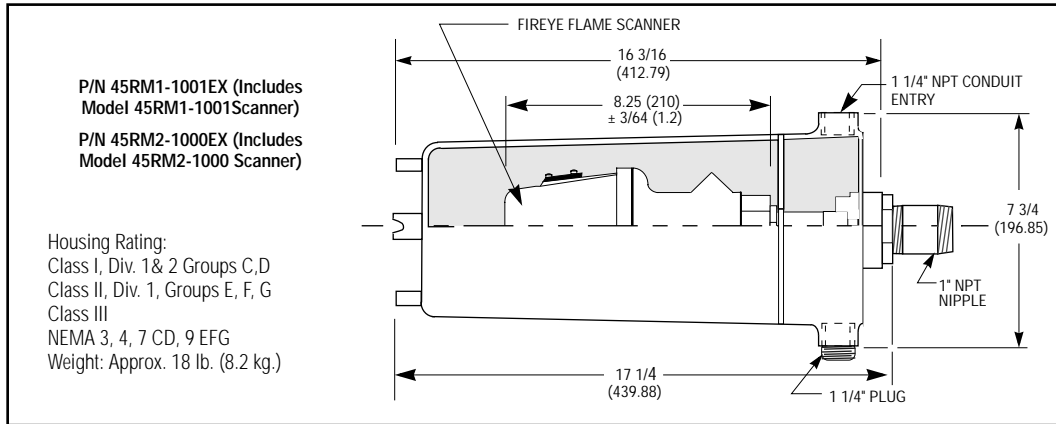

## INSTALLATION

Type 45RM1 and 45RM2 Scanners signal the presence and absence of flame by detecting red and infrared radiation emanating from the primary combustion zone (region of ignition) of a flame (see Figure 4). This highly turbulent region has a greater concentration of high frequencies (200-600 Hz) than a furnace fireball, background radiation or the remainder of the flame being monitored. For this reason, the scanner must be located so that the primary combustion zone is within the scanner's line of sight.

An acceptable scanner location must ensure the following:

- a. Reliable main flame and/or pilot flame detection at all air flows and furnace loads (ranges of fuel firing).
- b. Rejection of the pilot flame if too short or in the wrong position to ignite the main flame reliably, thus prohibiting the delivery of fuel to the burner.

FIGURE 5

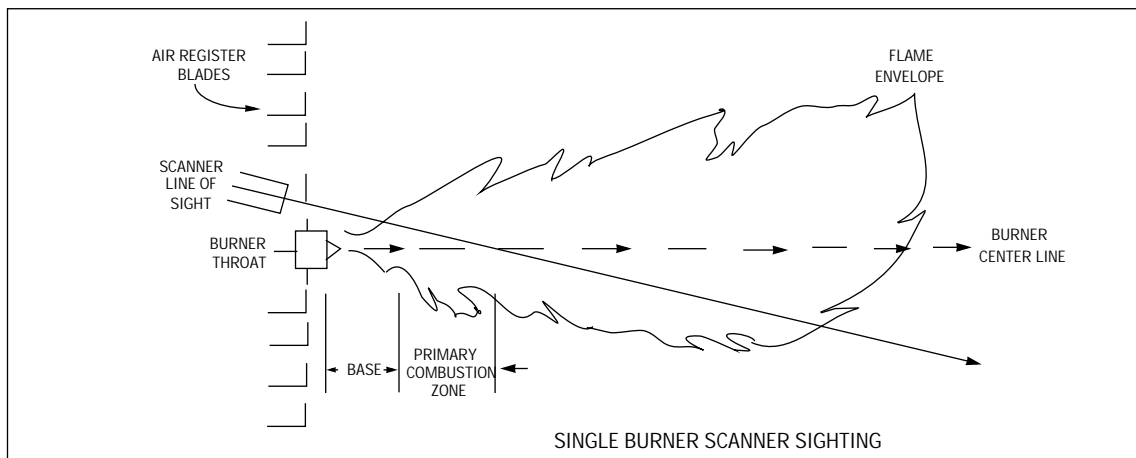
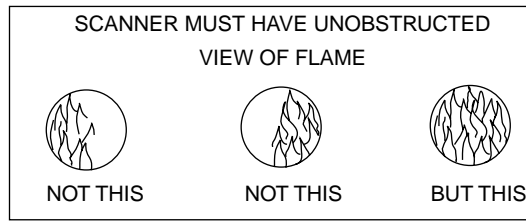

FIGURE 6



1. The best results are obtained when the scanner is aimed so that the scanner's line of sight intersects the burner center line at a slight angle (5 degrees) and sees a maximum of the primary combustion zone, as shown in Figure 4. If only one scanner is used per burner, the line of sight should also intersect the pilot flame
2. In installations where separate scanners are used to monitor main and pilot flames. the main flame scanner should be sighted so as not to detect pilot flame.
3. The scanner should have an unrestricted view of flame as far as possible. Physical obstructions such as air register blades, interfering vanes, or other hardware should be cut away or notched so they do not fall within the scanner's line of sight as shown in Figure 6.
4. Consideration must be given to burner secondary air rotation (some burners have clockwise air rotation and others counter-clockwise). If combustion air enters the furnace with a rotational movement of sufficient velocity to deflect pilot flame in direction of rotation, position the scanner 10 to 30 degrees downstream of the pilot burner as shown in Figure 6 and close to the periphery of the throat where the infrared radiation is at a maximum (see Figure 4).
5. Having determined an approximate location for the sight pipe, cut a clearance hole for a 2 inch pipe through the burner plate. Look through the hole! If register vanes interfere with the desired line of sight, the interfering vane(s) should be trimmed to assure an unobstructed viewing path at all firing levels as indicated in Figure 6.

 **CAUTION: Protective Filtered Lenses should be worn when viewing flame. Infrared and ultraviolet energy can be damaging to the eyes.**

FIGURE 7



6. The preferred method for mounting surface mounted scanners requires the use of a swivel mount, Part No. 60-1664-3 (NPT), shown in Figures 8, 9, and 10. Center the swivel mount over the 2 inch hole in the burner plate and secure using three hex head cap screws (not provided). Install the sight pipe on the swivel mount. If a swivel mount is not used, insert the end of the sight pipe into the hole, align the pipe to the desired viewing angle and tack weld (welding must be adequate to temporarily support the weight of the installed scanner). The sight pipe should be arranged to slant downward so that dirt and dust will not collect in it.

**NOTE:** Use no more than one foot of one inch sight pipe. Increase the sight pipe diameter one inch for every additional foot of sight pipe length used to avoid restricting the scanner's field of view

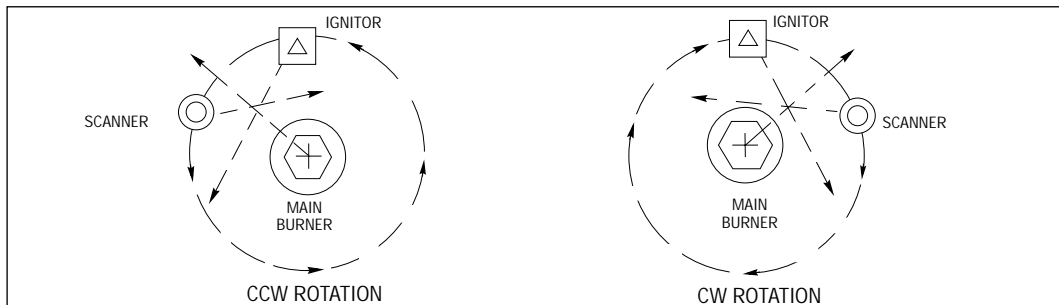
7. When a satisfactory sighting position has been confirmed by operational testing (see section on alignment), secure the swivel mount's ball position in place by tightening the three hex head cap

screws located on the swivel mount ring. If a swivel mount is not used, firmly weld the sight pipe in place.

8. Install the scanner on the sight pipe with its electrical fitting facing downward. Use a watertight fitting.
9. The scanner lens must be kept free of contaminants (oil, smoke, soot, dirt) and the scanner temperature must not exceed its maximum rating of 150° F (65° C). Excessive temperatures will shorten scanner life. Both requirements will be satisfied by continuous injection of purge air at either the 3/8" housing inlet or at a 1" wye ahead of the swivel mount. The scanner mounting may be made with provision for purge air through only the 3/8" opening or for purge air through either the 3/8" opening or the 1" wye connection as shown. In the latter arrangement normally only one of the two connections is provided with purge air and the other connection is plugged. When a sealing union is used, the 1" wye connection is used for the purge air (plug 3/8" opening) Under normal conditions, with clean burning fuels and moderate ambient temperature conditions, purge air flow of approximately 4 SCFM (113 L/min) is generally adequate. Up to 15 SCFM (425 L/min) may be required for fuels that may produce high levels of smoke or soot or for hot environments to maintain the scanner's internal temperature within specification.

## PIPING ARRANGEMENTS

FIGURE 8

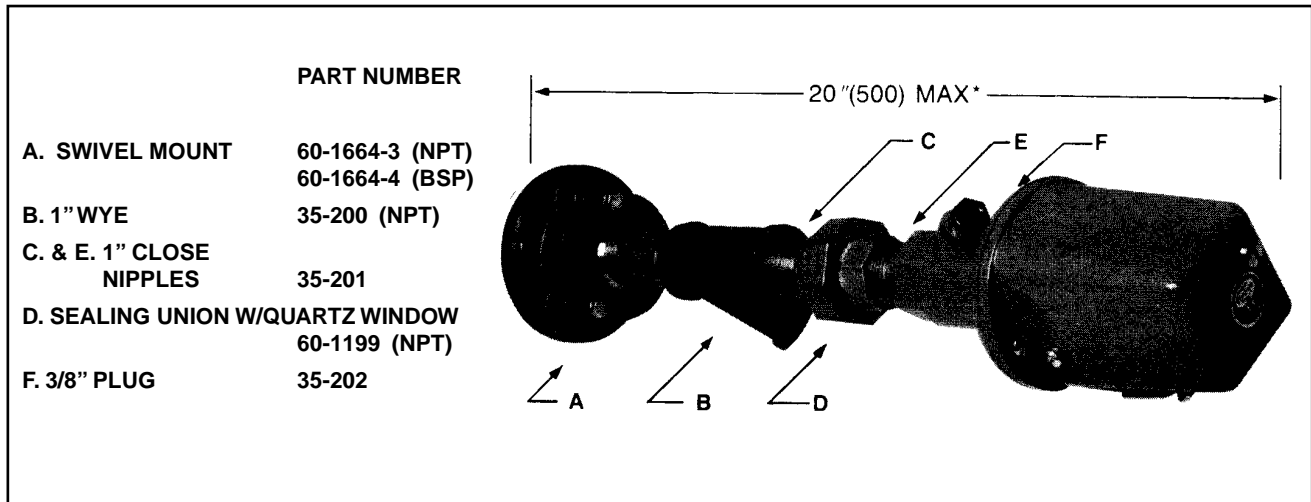

FIGURE 9

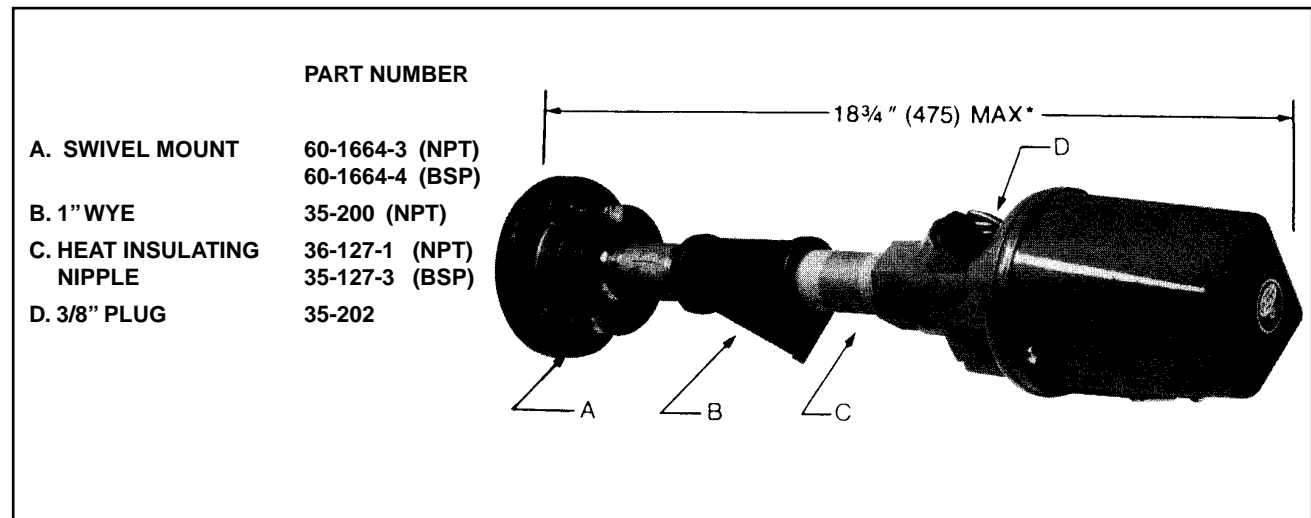
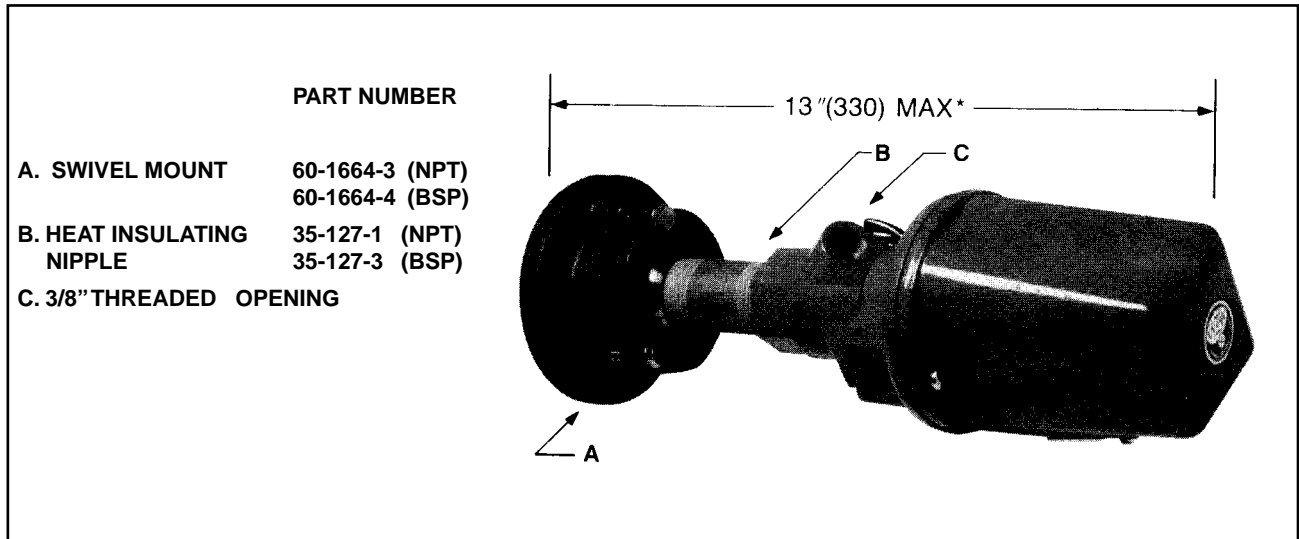

FIGURE 10



## ALIGNMENT AND ADJUSTMENTS

The following procedures are recommended to ensure optimum flame detection and discrimination. Flame discrimination is the ability to see only one burner or one pilot with other burners or pilots operating nearby. These procedures should be used whenever parts are replaced, when the scanner has been moved, when the flame shape is altered (additional fuels, new burners, burner/register modifications) as well as on all new installations. Signal readings referred to in this procedure are as displayed on an optional Flame Signal Meter. **Refer to the appropriate Flame Safeguard Control bulletin for sensitivity or threshold adjustment procedures.**

### (A) Pilot Flame Scanner

1. Apply power to scanner and associated control
2. Start pilot.
3. Adjust scanner sighting to detect pilot flame in the manner shown in Figure 6.
4. If flame signal meter readings fluctuate widely, readjust scanner sighting until highest, steadiest reading is obtained.
5. When the proper signal reading has been obtained, make sure that the scanner and the associated control do not respond to the ignition spark. This is accomplished by cutting off the fuel to the pilot and attempting to start the pilot using the spark igniter only. If the system responds to the spark, the scanner's sighting should be realigned.



**CAUTION:** Do not increase the control's sensitivity any more than is necessary to provide proper detection of the minimum pilot. Minimum pilot is the minimum flame required to satisfactorily ignite the main burner. Be sure to test for a reliable flame signal under maximum air flow conditions when the pilot may be deflected outside the line of sight. If this occurs, resighting is required.

### (B) Main Flame Scanner.

1. Apply power to scanner and associated control.
2. Start pilot.
3. Adjust scanner sighting so that ignition spark and pilot flame are not detected. Test should be conducted with maximum pilot flame and with both minimum and maximum airflow.
4. Start main burner.

5. Adjust scanner sighting to detect main burner flame. When sighting is correct (see Figure 6) the flame signal should be steady without extreme fluctuations in the signal reading.
6. When proper signal is established, manually close off the main burner fuel supply. When burner flame becomes unstable or is extinguished, the associated control should register a "No Flame" condition
7. Start an adjacent burner and vary its firing rate under normal airflow conditions. Make certain that the main flame scanner on the burner not in service does not respond to the adjacent burner. Readjust sighting if necessary.
8. Since the flame in the furnace interior masks the primary combustion zones of opposing burners, these need not be taken into account when the mounting location is selected.

## ACCESSORIES

FIGURE 11

<p>A. THROUGH I. ORIFICES .062 TO .5 DIA.          J. 34-181 ORIFICE RETAINER          K. 35-127-1 (NPT) HEAT INSULATING NIPPLE          35-127-3 (BSP) HEAT INSULATING NIPPLE          L. 46-87 SCANNER LENS          M. 92-48 SEALING UNION QUARTZ WINDOW          N. 101-78 DIODE</p>																												
<p>FIGURE #    PART #                    DESCRIPTION</p>	<table border="1"> <tr> <td>11A</td> <td>53-121-2</td> <td>ORIFICE .062" DIA.</td> </tr> <tr> <td>11B</td> <td>53-121-3</td> <td>ORIFICE .078" DIA.</td> </tr> <tr> <td>11C</td> <td>53-121-4</td> <td>ORIFICE .093" DIA.</td> </tr> <tr> <td>11D</td> <td>53-121-5</td> <td>ORIFICE .109 DIA.</td> </tr> <tr> <td>11E</td> <td>53-121-6</td> <td>ORIFICE .125 DIA.</td> </tr> <tr> <td>11F</td> <td>53-121-7</td> <td>ORIFICE .187 DIA.</td> </tr> <tr> <td>11G</td> <td>53-121-8</td> <td>ORIFICE .250 DIA.</td> </tr> <tr> <td>11H</td> <td>53-121-9</td> <td>ORIFICE .375 DIA.</td> </tr> <tr> <td>11I</td> <td>53-121-10</td> <td>ORIFICE .500 DIA.</td> </tr> </table>	11A		53-121-2	ORIFICE .062" DIA.	11B	53-121-3	ORIFICE .078" DIA.	11C	53-121-4	ORIFICE .093" DIA.	11D	53-121-5	ORIFICE .109 DIA.	11E	53-121-6	ORIFICE .125 DIA.	11F	53-121-7	ORIFICE .187 DIA.	11G	53-121-8	ORIFICE .250 DIA.	11H	53-121-9	ORIFICE .375 DIA.	11I	53-121-10
11A	53-121-2	ORIFICE .062" DIA.																										
11B	53-121-3	ORIFICE .078" DIA.																										
11C	53-121-4	ORIFICE .093" DIA.																										
11D	53-121-5	ORIFICE .109 DIA.																										
11E	53-121-6	ORIFICE .125 DIA.																										
11F	53-121-7	ORIFICE .187 DIA.																										
11G	53-121-8	ORIFICE .250 DIA.																										
11H	53-121-9	ORIFICE .375 DIA.																										
11I	53-121-10	ORIFICE .500 DIA.																										

FIGURE 12

<p>A. 60-1664-3 (NPT) SWIVEL MOUNT          60-1664-4 (BSP) SWIVEL MOUNT          B. 60-1199 (NPT) SEALING UNION W/QUARTZ WINDOW          C. 59-221 SCANNER CABLE</p>	
---	--

**FIGURE 13 ORIFICE LOCATION**

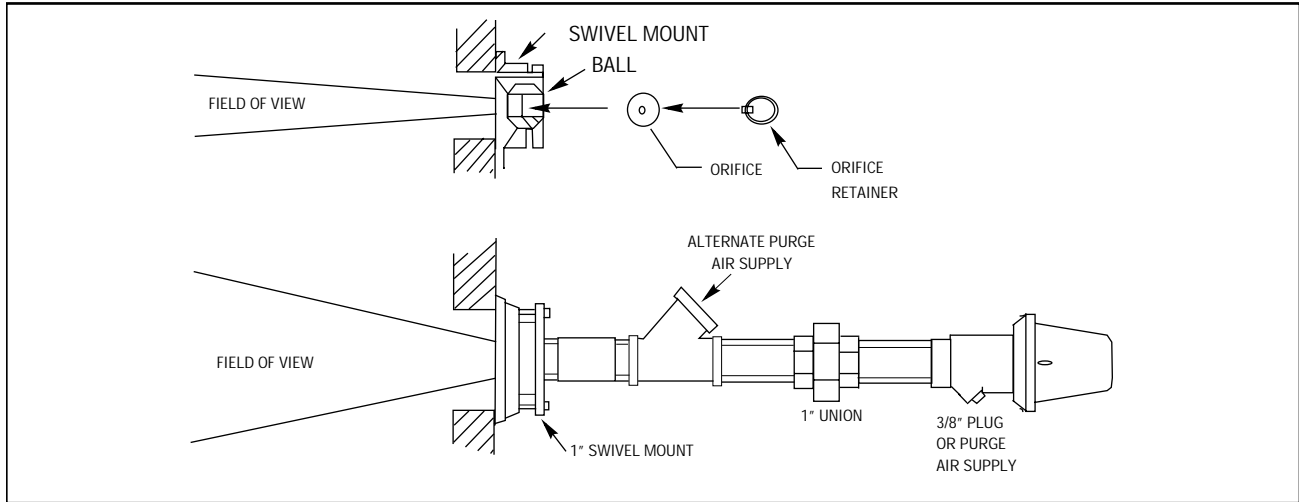

## USE OF SCANNER ACCESSORIES

### Swivel Mount

The scanner swivel mount, P/N 60-1664-3 (NPT) (see Figure 11 Item A), is used to adjust the scanner sighting angle after the scanner has been installed. The swivel mount is used as indicated in Figures 7, 8 and 9.

### Orifices

The Orifice (Figure 11, Items A-I) is used to restrict field of view (target area), reduce air flow, maintain air block, and increase scanner sensitivity. The orifice is secured within the ball of a swivel mount with an orifice retainer, or the orifice can be placed within a 1 inch union (not provided) (See Figure 13).

*NOTE: There is an inverse relationship between discrimination and sensitivity*

Ideally, the scanner should sight a target area of 8 to 25 square inches (50-150 cm<sup>2</sup>) of the flame front. The flame front is a plane within the combustion space separating the region of unburned fuel from the burning fuel. For example if a 1/2 inch diameter orifice is placed within the ball of a swivel mount one foot from the scanner lens and the swivel mount is located on the surface of a 4 foot deep windbox and if the range of stable flame is 5 feet beyond the windbox, the flame front target area is 19.6 sq in as shown in Figure 14.

### Heat Insulating Nipple

The heat insulating nipple, Part No 35-127-1 (NPT) (see Figure 10, Item K). is used to prevent heat transfer from the hot sight pipe to the scanner head.

### Sealing Union w/Quartz Window

The sealing union, P/N 60-1199 (see Figure 11, Item B), is used whenever a coupling or a seal is required for scanner piping. The quartz window blocks furnace pressure, heat, gases and soot from coming in contact with the scanner and contaminating the lens. The size is one inch U.S. standard taper pipe thread (Schedule 40, 1"-1 1/2" NPT). When the sealing union is used, a 1' wye fitting must be used down stream of it for connection of a purge air supply (plug 3/8" opening). See Figure 8 for piping with the sealing union, Item B.

### Electrical Accessories

The diode (101-78) is used whenever a type 45RM1 or 45RM2 scanner is operated with a type 45UV5 scanner. Refer to the wiring diagrams for further information. Fireye scanner cable,



P/N 59-470 (see Figure 12, Item C) is used for wiring connections between the scanner(s) and the control terminals. Each wire is color coded for connection as follows:

- Black—is used for the “P” or AC hot terminal
- Red—is used for the “1” or shutter terminal.
- White—is used for the “C” or common terminal.
- Green—is shielded and is used for the “14” or flame signal terminal.

Connect the shield to terminal C at the control end only; the shield at the scanner end should be left disconnected. (See wiring diagrams).

**FIGURE 14** SCANNER WITH ORIFICE

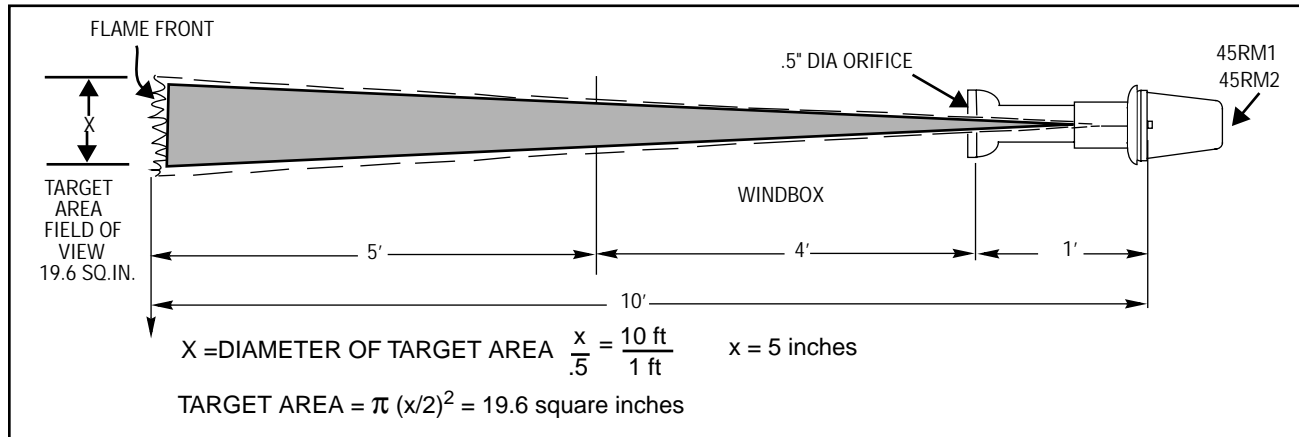

## CONTROL AND SCANNER WIRING

All wiring to the scanner should be rated at 600 volts and 90° C. For runs less than 1000 feet, Fireye recommends the use of scanner cable P/N 59-470 (4 conductors 18 AWG, 2 conductors 22 AWG, common shield). For runs in excess of 1,000 feet consult the factory. For ease of installation and occasional service the wires should be routed to the screw terminals in the scanner via a flexible conduit per the following groups. Always refer to the appropriate flame safeguard control bulletin.

### Group I Fireye Controls

A blocking diode, Fireye P/N 101-78 must be used when a solid state type scanner is used in parallel with an UV scanner. Connect the diode in series with the lead from terminal 14 in the UV scanner as shown in Figure 15. This is to avoid damaging the solid state scanner. If the application requires that only one scanner be in use at any time, the other unit can be removed from operation by breaking the power lead (LA or LB).

### Group II Fireye Controls

If the intended use requires that the amplifier input signal come from one of two or more scanners, the power and shutter drive signals should be switched between scanners using a single relay “S” or selector switch. This permits the operation of one scanner at a time. As with Group I amplifiers, the blocking diode is necessary when using the solid state scanner with a UV unit (see Figure 16).

### Group III Fireye Controls (non -self-checking type)

With these amplifiers, terminal 1 on the scanner, the self-checking shutter connection, is not used. If more than one scanner is used, power for additional units can be obtained from terminal 1 of the amplifier through a 0.33  $\mu\text{F}$  capacitor (P/N 7-1143) and 1 meg ohm, 1/4 watt resistor. With the connections as shown the unwanted scanner can be turned off by breaking the power lead at LA or 1A. As with Group I and II amplifiers, the diode should be used when a solid state scanner is used with a UV unit (see Figure 17).

### Group IV Amplifiers (25SU3-5170 Series)

A blocking diode is not required when a solid state scanner is used with a UV unit (see Figure 18).

#### NOTES:

1. Connect the scanner cable shield to terminal C at the control end only; the shield at the scanner end should be left disconnected.
  - Strip six inches of insulation from scanner end of cable.
  - Cut off the six inches of cable shield that is visible.
  - Tape the cable's insulation where it terminates so the cable shield is not visible.
2. Flame amplifier rack, P/N 60-1706 has a blocking diode between terminals 14A and 14D.

### Group V Amplifiers (5000 Series)

A blocking diode, Fireye P/N 101-78, must be used when a solid state scanner is used in parallel with a UV scanner. Connect the diode in series with the lead from the terminal 14 in the UV scanner as shown in figure 20.

### Group VI Amplifiers (2000 Series)

A blocking diode is not required when a solid state scanner is used with a UV unit (see Figure 21).

**FIGURE 15**      **GROUP I CONNECTIONS**

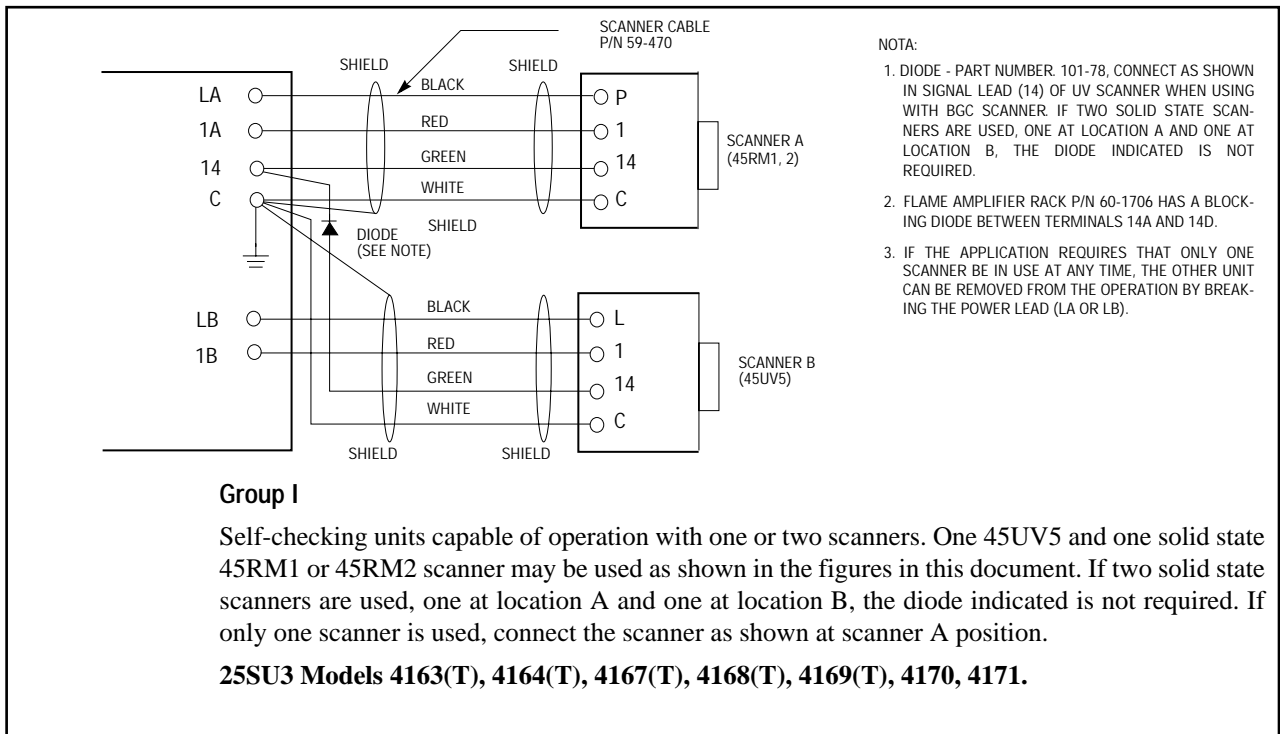

**FIGURE 16 GROUP II CONNECTIONS**

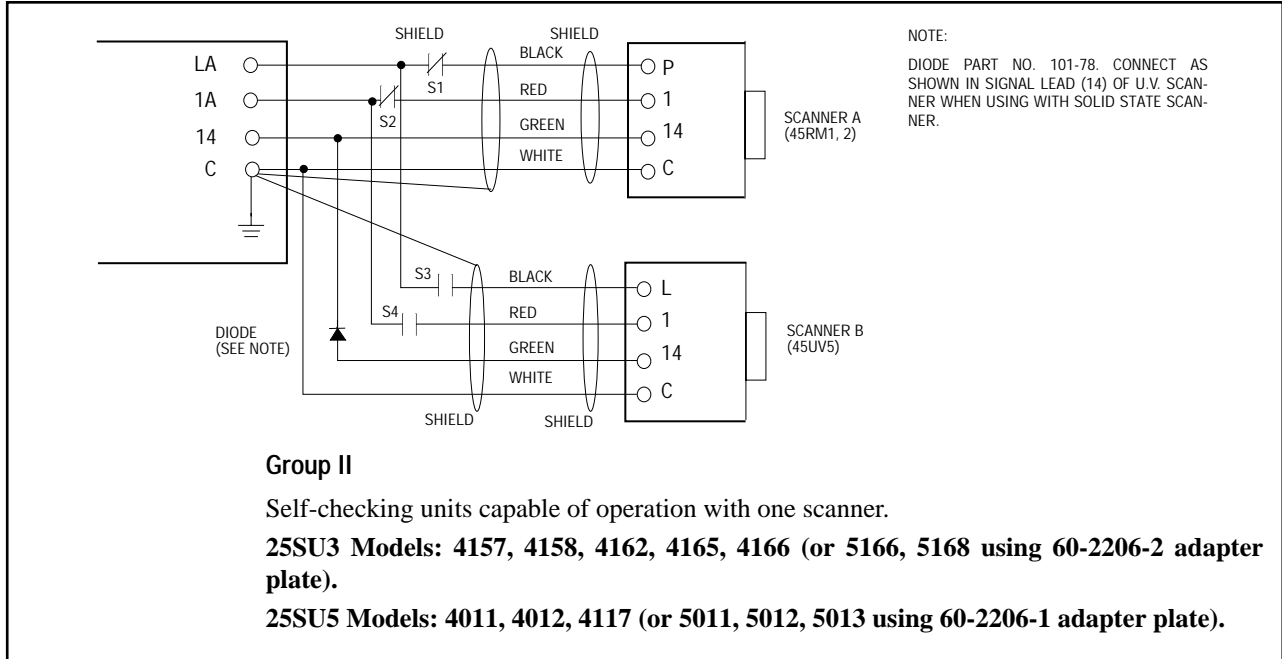

**FIGURE 17 GROUP III CONNECTIONS**

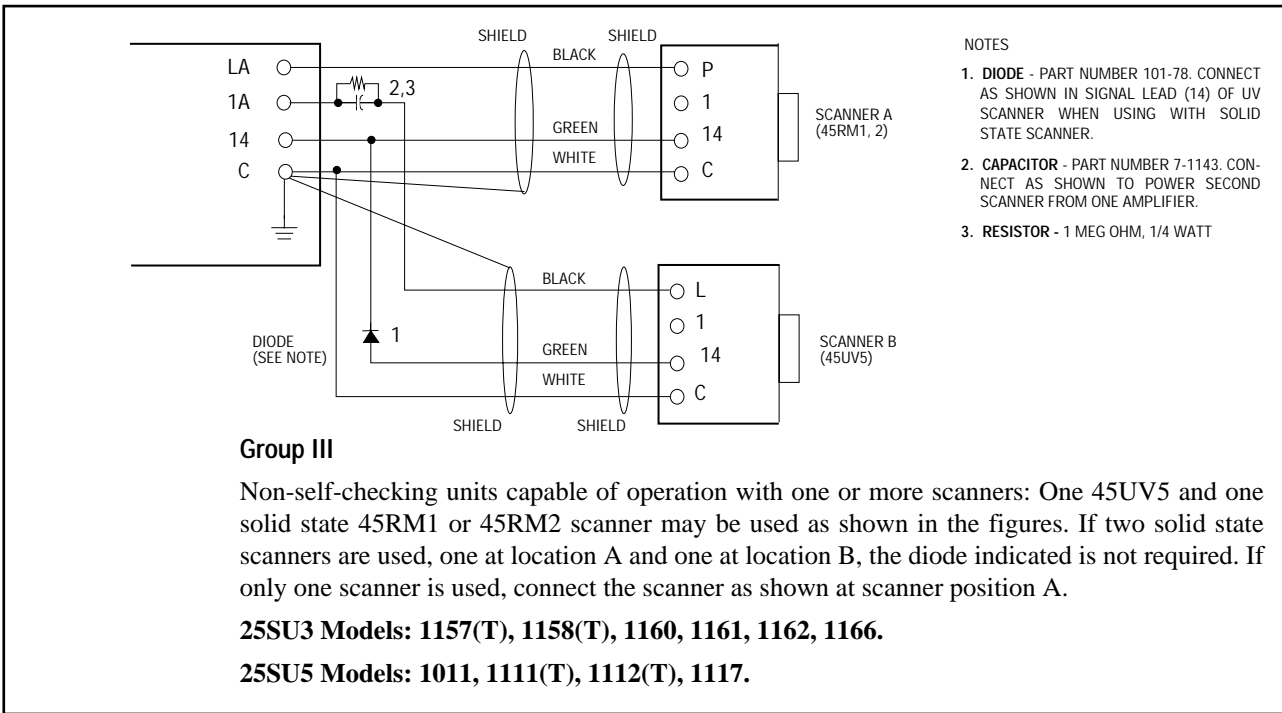

**FIGURE 18 GROUP IV CONNECTIONS**

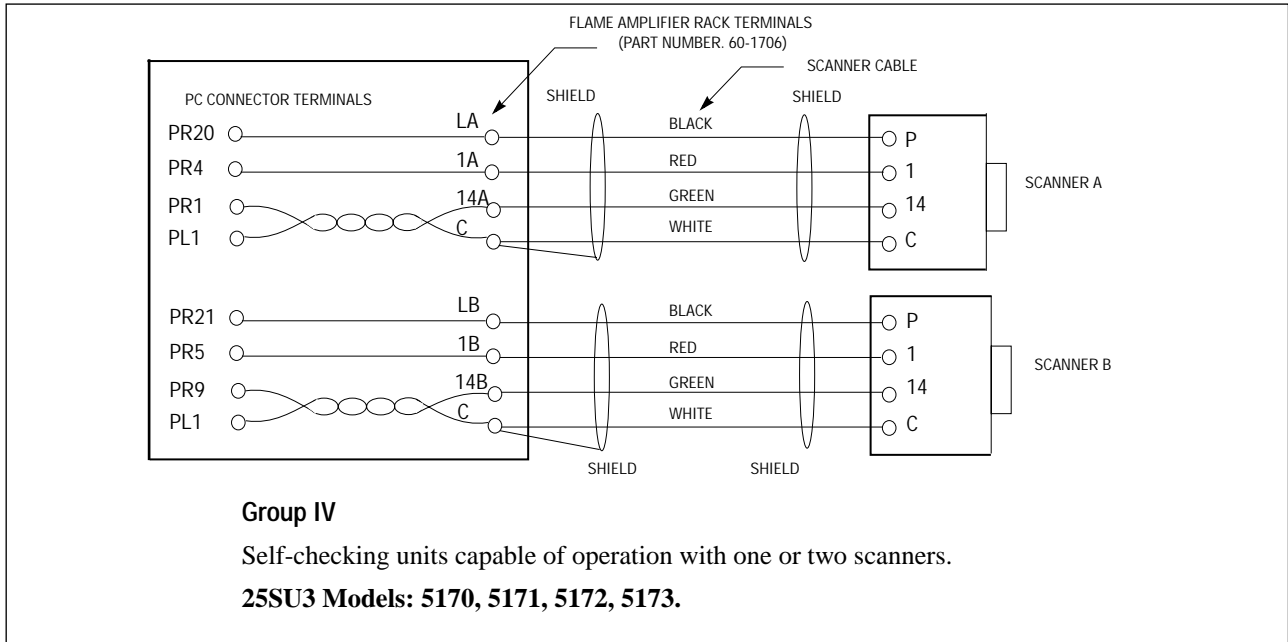

**FIGURE 19 BLOCKING DIODE CONNECTIONS**

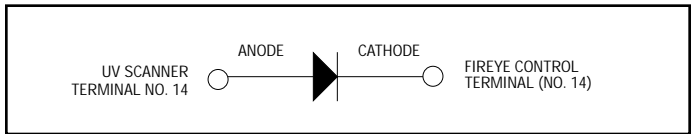

**FIGURE 20 GROUP V CONNECTIONS**

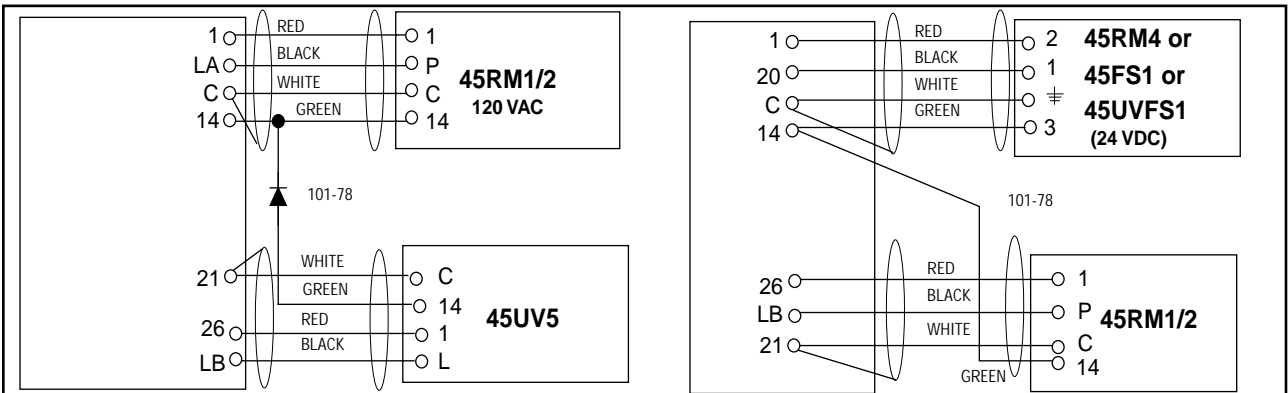

**Group V**

Self-checking units capable of operation with one or two scanners. One 45UV5 and one solid state 45RM1 or 45RM2 scanner may be used as shown in the figures. If two solid state scanners are used, one at location A and one at location B, the diode indicated is not required. If only one scanner is used, connect the scanner as shown at scanner position A.

Connect scanner cable shield(s) to wiring base terminal C. The shield at the 45UV5, 45RM1, or 45RM2 scanner end is left disconnected. The shield at the 45RM4, 45FS1, or 45UVFS1 scanner end is tied to the scanner cable quick-disconnect.

**25SU3 Models: 5166, 5168 (wiring base 60-2206-2)**

**FIGURE 21 GROUP VI CONNECTIONS**

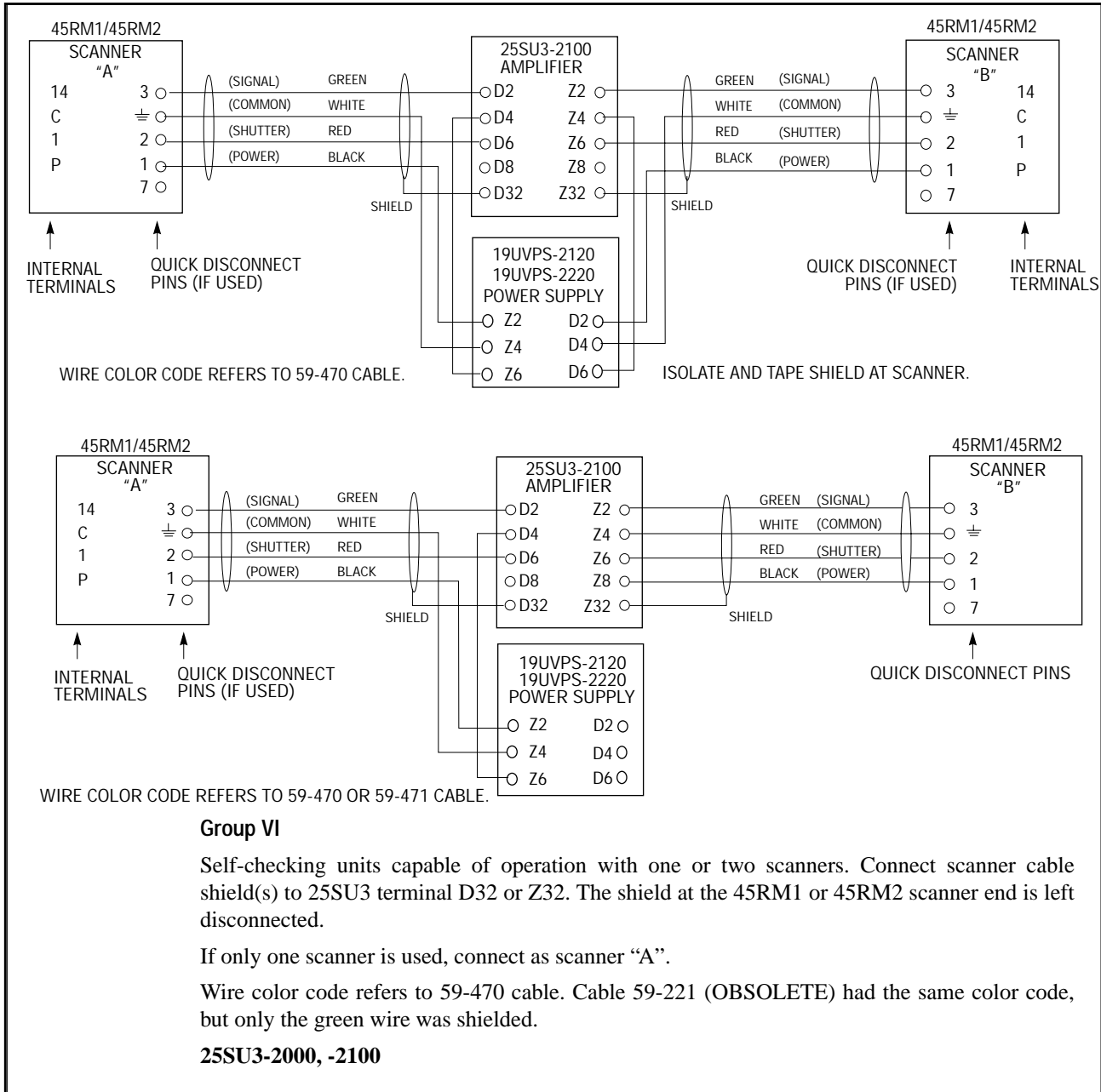

**SPECIAL APPLICATIONS**

Where unusually deep windboxes are involved and/or the distance from a surface mounted scanner to the flame front is greater than 12 feet (3.66m) such as on a large rotary kiln use a long range lens assembly P/N 60-1622 (Figure 19). Using this assembly, the field of view is kept small while the large lens surface gathers more radiation from each actively used point on the ignition zone surface. Prepare a standard 45RM1 or 45RM2 as follows: Remove the flange. Remove one screw from the metal lens holder. Loosen the other screw, swing away the lens holder, replace the first screw and tighten down. Now repeat with the second screw. Scanner is now ready to be fastened by means of the two filister head screws and "keyhole" slots to the long-range lens assembly. Apply a 2 1/2 inch US NPT or equivalent pipe nipple to the mounting surface of the burner or boiler sight port as close as practical to the burner center line and oriented parallel to it. Sight the scanner close to the center of the flame front yet far enough out so that flame rather than unburned fuel persists in the target area.

No restriction needs to be introduced into the arrangement. Turn down the sensitivity to determine the margin for consistent operation. Leave the sensitivity as high as possible short of encountering discrimination problems when the installation and testing are finished.

FIGURE 22

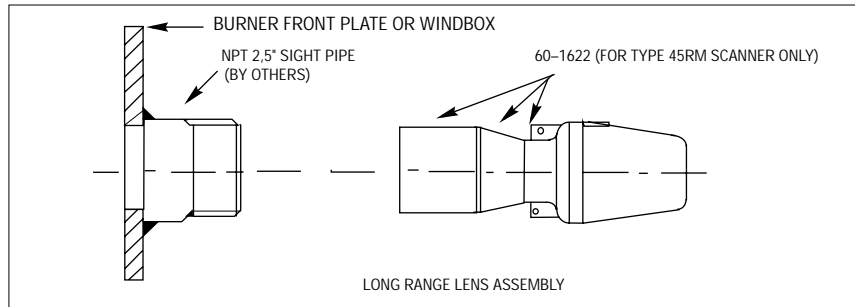

## MAINTENANCE

**Humidity Effects:** It is considered good practice to minimize any possible adverse effects of high humidity by keeping electronic equipment continuously powered even during periods when it is not in use.

**Scanner:** If continuous air purging of the scanner sight pipe is not completely effective in preventing viewing window contamination a schedule should be set up for periodically cleaning the window. Always use a soft clean (non-oily) cloth to wipe the window. For maximum assurance that oily films will be removed, wash first with a cloth dampened (not dripping) with a concentrated detergent solution.



**Caution: Disconnect or shut off electric power when working on scanner. Use original Fireye repair parts to maintain optimum operation.**

## RECOMMENDED SPARE PARTS

FIGURE 23

FIGURE #	PART #	DESCRIPTION
22A	61-4468	SHUTTER ASSEMBLY
22B	28-248	FLANGE GASKET
22E	61-2275-3	GLASS LENS ASSEMBLY

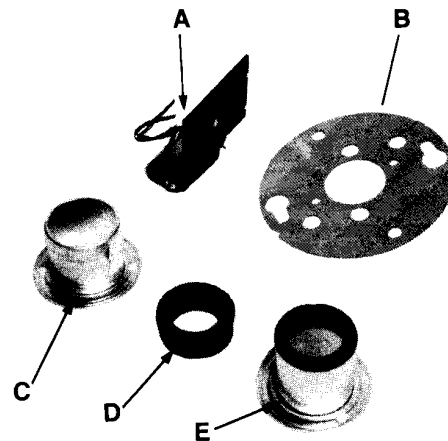

Original equipment factory replacement parts are available at various sub-assembly levels. For example, in Figure 23, item E, the Glass Lens Assembly (61-2275-3) contains three parts which can be inserted as a unit.

- A. 61-4468 SHUTTER
- B. 29-248 GASKET
- C. 82-95 LENS HOLDER
- D. 16-103 LENS RETAINER
- E. 61-2275-3 GLASS LENS ASSEMBLY



---

## TROUBLESHOOTING

The following steps should be performed if flame is not detected:

1. Check scanner wiring for breaks and proper connections.
2. Look down the sight pipe.
  - Scanner should have an unrestricted view for all firing conditions.
  - The flame's primary combustion zone (first 1/3 of flame) should be within the scanner's field of view for all firing loads.

*NOTE: Wear protective filtered lenses when viewing flame.*

3. Clean the scanner lens with a glass detergent or glass cleaning agent which contains no abrasives. After cleaning remove all cleaning films with a soft lint-free cloth.
4. Listen to see if scanner shutter is operating, there should be 16 VDC (cycling) between scanner terminals 1 and C. With amplifier models 25SU3-4169T, 5166, 5168 and 25SU%-5011, 5012, 5013, the shutter voltage is present only when the flame is detected.
5. Measure voltage across scanner terminals.
  - a. Between terminals 14 and C there should be 12VAC pulses of 40 microseconds.
  - b. Between terminals P and C there should be:
    - 55 to 75 VAC when using a type 45RM2 scanner.
    - 150 to 180 VAC when using a type 45RM1 scanner.
6. Scanner operation can be checked by aiming it at a fluorescent, or high intensity light and waving your hand in front of the scanner's lens. The meter on the associated control should indicate flame.
7. Check to see that an external selector switch is connected to the associated control's sensitivity/threshold select or scanner enable terminals, if applicable.
8. Reposition scanner so it is properly aligned for best flame signal.

*NOTE: When Fireeye products are combined with equipment manufactured by others and/or integrated into systems designed or manufactured by others, Fireeye's warranty, as stated in its General Terms and Conditions of Sale, pertains only to the Fireeye products and not to any other equipment or to the combined system or its overall performance.*









---

## NOTICE

When Fireeye products are combined with equipment manufactured by others and/or integrated into systems designed or manufactured by others, the Fireeye warranty, as stated in its General Terms and Conditions of Sale, pertains only to the Fireeye products and not to any other equipment or to the combined system or its overall performance.

---

## WARRANTIES

FIREYE guarantees for *one year from the date of installation or 18 months from date of manufacture* of its products to replace, or, at its option, to repair any product or part thereof (except lamps, electronic tubes and photocells) which is found defective in material or workmanship or which otherwise fails to conform to the description of the product on the face of its sales order. **THE FOREGOING IS IN LIEU OF ALL OTHER WARRANTIES AND FIREYE MAKES NO WARRANTY OF MERCHANTABILITY OR ANY OTHER WARRANTY, EXPRESS OR IMPLIED.** Except as specifically stated in these general terms and conditions of sale, remedies with respect to any product or part number manufactured or sold by Fireeye shall be limited exclusively to the right to replacement or repair as above provided. In no event shall Fireeye be liable for consequential or special damages of any nature that may arise in connection with such product or part.



FIREYE  
3 Manchester Road  
Derry, New Hampshire 03038 USA  
[www.fireeye.com](http://www.fireeye.com)

CU-26  
FEBRUARY 2000  
Supersedes Nov. 1993