

45RM4 SCANNER MODELS 1000, 1001 (Including EX and CEX Models)

24VDC OPERATION

Year 2000 Compliant in accordance with BSI document DISC PD2000-I:1998

IMPORTANT: This bulletin is directed to the licensed boiler service technicians and professional combustion engineers who are experienced in the installation and operation of FIREYE flame safeguard controls. Persons not experienced with Fireeye flame safety products should contact the nearest FIREYE representative, or a qualified service group for assistance.



WARNING: IMPROPER INSTALLATION OF THESE PRODUCTS MAY BE HAZARDOUS TO LIFE AND PROPERTY.

DESCRIPTION

The FIREYE® Type 45RM4 flame scanners are self-checking, flame sensing devices. They consist of a lens, photodetector, and a solid-state, frequency tuned circuit contained in a die-cast aluminum housing. When powered by a compatible, self-checking Fireeye flame safeguard control, the scanner detects the presence and absence of flames having certain characteristics.

The 45RM4 has a 16-position rotary selector to select the ideal flame “flicker” frequency. This is effective in detecting and discriminating Flame ON and Flame OFF conditions on installations where low frequency emissions predominate (pulverized coal, lo-nox, etc.), as well as mid-range frequency applications (natural gas). This allows type 45RM4 scanners to discriminate between the targeted flame and background flame for a wide range of applications and fuels.

The 45RM4 scanner incorporates a large area lead sulfide cell to detect a wide variation of background brightness without cell washout. An integral 10 segment Flame LED bargraph is provided to assist in the installation and sighting of the scanner.

The scanner uses an “electronic shutter” assembly to replace the electro-mechanical shutter. A shutter pulse from the flame amplifier is still required to activate the shutter.

The scanner is powered by 24VDC provided from an external power supply or by an existing flame amplifier such as the 25SU3 or 25SU5 series. 24VDC operation reduces electrical noise frequencies resulting from 120VAC operation (e.g. 60HZ, 120HZ, etc.). A quick disconnect has also been incorporated into the scanner to provide ease of installation and removal.



APPLICATION

When properly sighted, the 45RM4 scanner can discriminate the target flame from adjacent flames and/or background radiation. It can also be used to detect pilot and main, discriminating the pair from background conditions. These unique design features enable the scanners to be applied, in conjunction with a compatible Fireeye flame safeguard control, on single and multiple burner fired apparatus including power, industrial process and electric utility furnaces and boilers, to provide ignition and flame failure protection.



WARNING: The response of the scanner depends on burner configuration as well as on the turbulence and spectral characteristics of the flames. Application assistance is available on request.

OPERATION

Type 45RM4 Scanners use the modulation occurring within a flame that is produced by wave lengths in the visible and near infra-red range. The scanner discriminates between the targeted burner and the background (e.g.: a fireball or flame from other burners, etc.) by observing the amount of signal resulting from the band pass filter in the scanner. The target burner will also have more signal at the selected frequency than the background. The 16 position rotary switch allows the band pass filter to be selected to the appropriate frequency for the application. Many lo-nox applications and lazy fires have the highest signal differential at the lower frequency settings (e.g. 20-100 Hz).

The detector board of the scanner consists of a current to voltage convertor with a feedback loop to maintain the DC voltage output at its maximum. This DC voltage is a function of the background brightness. By holding this DC voltage at its maximum, the maximum AC flame signal is achieved.

This AC signal is then applied to a switched capacitor digital filter. The filter is configured as a band-pass amplifier whose center frequency is dependent on the 16 position rotary switch.

The output of this filter is then connected to a full wave rectifier. The output of the rectifier is used to illuminate the Flame LED bargraph, as well as feed the power supply/output board which processes the signal for transmission to the amplifier (Type 25SU3 or 25SU5). The LED can be used to indicate sufficient signal to energize the flame relay at the flame amplifier. This Flame LED bargraph assists in aligning the scanner to the flame being scanned.

Also included in the scanner is an “electronic shutter” assembly that permits the self-checking circuit within the associated Fireeye control to verify that the scanner and signal circuits are operating properly in the absence of flame signal. The scanner provides pulses to the flame amplifier during shutter open intervals. During shutter close intervals, the cell is disabled, and the scanner pulses should be interrupted. The flame amplifier expects to see no pulses during the shutter closed interval and will shut down (de-energize the flame relay) if it does.

The 45RM4 scanners are compatible with the Fireeye Flame Safeguard controls listed in Figures 17, 18 and 19.

FIGURE 1 TYPE 45RM4 SCANNER DIMENSIONS

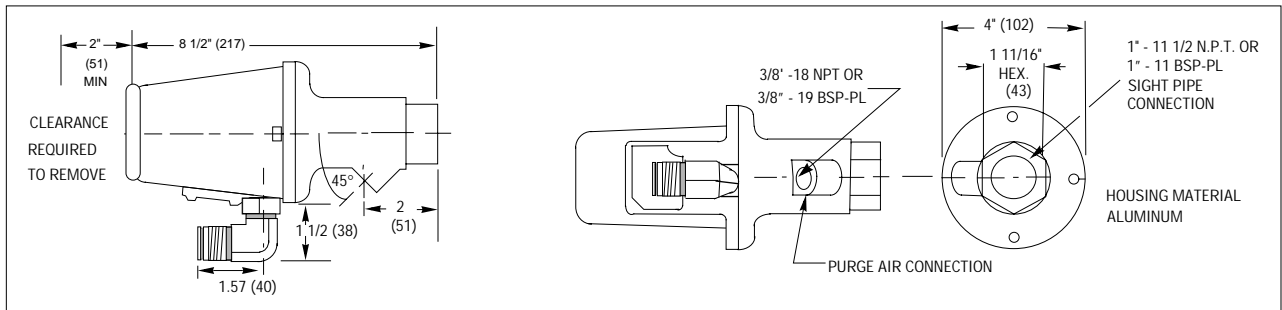

Optional Mounting Configurations for Hazardous Areas

FIGURE 2 45RM4 SCANNER IN NEC/NEMA HAZARDOUS AREA HOUSING

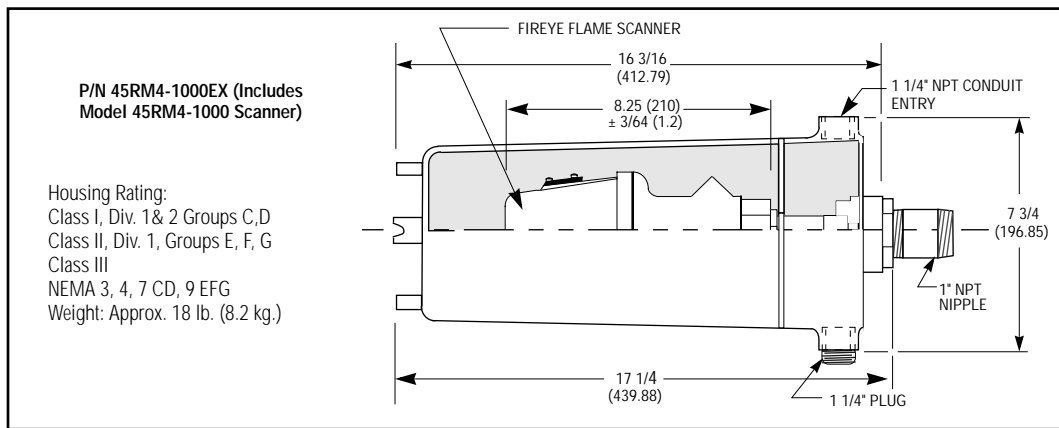
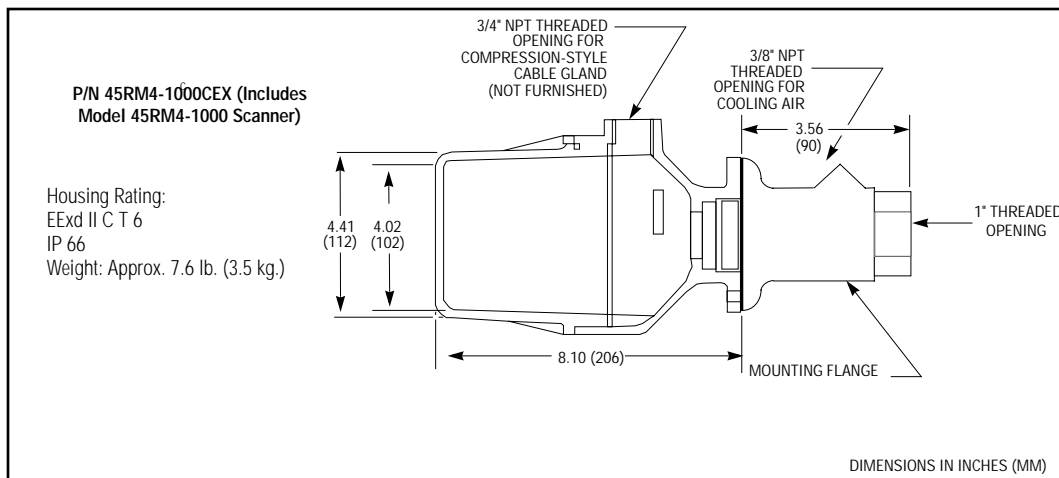

FIGURE 3 45RM4 SCANNER IN CENELEC HAZARDOUS AREA HOUSING



SPECIFICATIONS

Mounting

Surface Mounted Models are provided with 1- female thread mounting. Either US NPT or British (BSP) threads are provided according to model (see Table below).

Heat Insulating Nipple 1" - 11 1/2 or 11 BSP provided (refer to Figure 10K).

Housing Including Mounting Flange

Material: Die Cast Aluminum

Design: Mounting Flange, with Purge Air fitting to be permanently installed, carries two 1/4 - 20 screws when may be loosened for quick removal of the scanner electronics housing, such as for lens cleaning.



Weight: 2.4 Lbs. (1.1 kg)

	AGENCY APPROVALS	THREADS
45RM4-1000	CSA AND FM	NPT
45RM4-1001	CSA AND FM	BSP

Electrical

Power Requirements: 24VDC from associated Fireye control or 24VDC (+ 10%, -15%) from an external power supply. Current rating 100 mA per scanner.

Connection: Quick Disconnect. See Page 13.

Frequency Adjustment: Turn the 16 position rotary switch located under the cover on the rear of the scanner housing with a small screwdriver to the appropriate frequency.

Temperature Range

Maximum Operating: 150°F (65°C)

Minimum Operating: -40° F (-40°C)

Humidity: 0% to 95% R.H. Noncondensing.

Purge Air Flow Required

Source: Clean Ambient

Volume Required: 4.0 SCFM (113L/min) at $\frac{3}{8}$ inch threaded housing inlet or 1 inch “Y” fitting in scanner sight pipe. Temperature near the upper limit of the scanner operating range and/or use with dirty fuels may require up to 15 SCFM (425L/min).

Specifications subject to change without notice.

INSTALLATION

Type 45RM4 Scanners signal the presence and absence of flame by detecting red and infrared radiation emanating from the primary combustion zone (region of ignition) of a flame (see Figure 4). This highly turbulent region has a greater concentration of high frequencies (200-600Hz) than a furnace fireball, background radiation or the remainder of the flame being monitored. For this reason, the scanner must be located so that the primary combustion zone is within the scanner's line of sight. An acceptable scanner location must ensure the following:

1. Reliable main flame and/or igniter flame detection at all air flow and furnace loads (ranges of fuel firing).
2. Rejection of the igniter flame if it's too short or in the wrong position to ignite the main flame reliably, thus prohibiting the delivery of fuel to the burner.

FIGURE 4

Single Burner Scanner Sighting

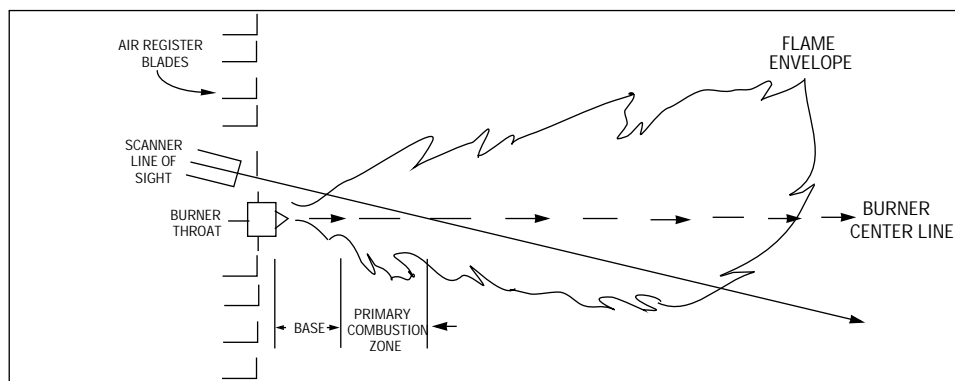

INSTALLATION PROCEDURE

1. The best results are obtained when the scanner is aimed so that the scanner's line of sight intersects the burner center line at a slight angle (e.g. 5 degrees) and sees a maximum of the primary combustion zone, as shown above. If only one scanner is used per burner, the line of sight should also intersect the igniter flame.
2. For installations where separate scanners are used to monitor main and ignitor flames, the main flame scanner should be sighted to not detect the ignitor flame.
3. The scanner should have an unrestricted view of the flame, as far as possible. Physical obstructions such as air register blades, interfering vanes, or other hardware should be cut away or notched so they do not fall within the scanner's line of sight as shown in Figures 4 and 6.
4. Consideration must be given to burner secondary air rotation (some burners have clockwise air rotation and others counterclockwise). If combustion air enters the furnace with a rotation with sufficient velocity to deflect the ignitor flame in the direction of rotation, position the scanner 10 to 30 degrees downstream of the ignitor as shown in Figure 5 and close to the periphery of the throat where the infrared radiation is at a maximum (see Figure 4).



WARNING: PROTECTIVE FILTERED LENSES SHOULD BE WORN WHEN VIEWING FLAME. INFRARED AND ULTRAVIOLET ENERGY CAN BE DAMAGING TO THE EYES.

5. Having determined an approximate location for the sight pipe, cut a clearance hole for a 2 inch pipe through the burner plate. Look through the hole! If register vanes interfere with the desired line of sight, the interfering vane(s) should be trimmed to assure an unobstructed viewing path at all firing levels as indicated in Figure 6.

FIGURE 5

Scanner Location vs. Secondary Air Location

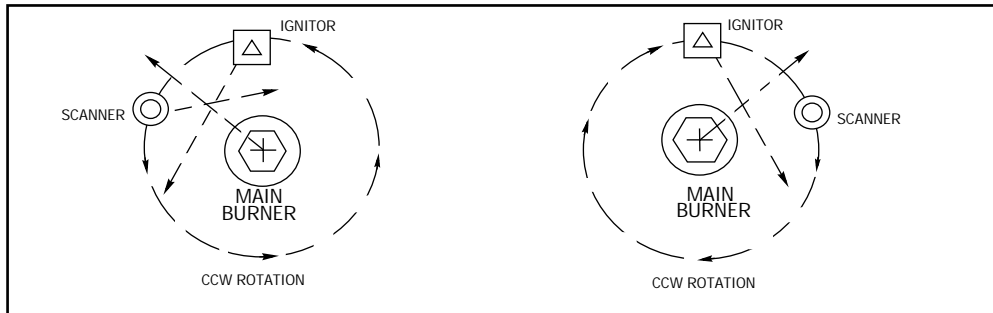

FIGURE 6



6. The preferred method for mounting surface mounted scanners requires the use of a swivel mount, P/N 60-1664-3 (NPT), shown in Figures 7, 8, 9, and 11. Center the swivel mount over the 2 inch hole in the burner plate and secure using three hexhead cap screws (not provided). Install the sight pipe on the swivel mount. If a swivel is not used, insert the end of the sight pipe into the hole, align the pipe to the desired viewing angle and tack weld (welding must be adequate to temporarily support the weight of the installed scanner). The sight pipe should be arranged to slant downward so that dirt and dust will not collect inside.



CAUTION: Use no more than one foot of one inch diameter sight pipe. Increase the sight pipe diameter one inch for every additional foot of sight pipe length used, to avoid restricting the scanner's field of view.

7. When a satisfactory sighting position has been confirmed by operational testing (see Set-Up Procedure), secure the swivel mount's ball position in place by tightening the three hexhead cap screws located on the swivel mount ring. If a swivel mount is not used, firmly weld the sight pipe in position.
8. Install the scanner on the sight pipe with its electrical fitting facing downward.
9. The scanner lens must be kept free of contaminants (oil, ash, soot, dirt) and the scanner temperature must not exceed its maximum rating of 150°F (65°C). Excessive temperatures will shorten scanner life. Both requirements will be satisfied by a continuous injection of purge air at either the $\frac{3}{8}$ " housing inlet or the 1 "Y" connection ahead of the swivel mount as shown in Figures 7 and 8.

The scanner mounting may be made with provision for purge air through only the $\frac{3}{8}$ " opening as shown in Figure 9 or for purge air through either the $\frac{3}{8}$ " opening or the 1 "Y" connection. In the latter arrangements, normally only one of the two connections is provided with purge air and the other connection is plugged. When a sealing union is used as shown in Figure 7, the 1 "Y" connection is used for the purge air (plug $\frac{3}{8}$ " opening).

Under normal conditions, with clean burning fuels and moderate ambient temperature conditions, purge air flow of approximately 4 SCFM (113L/min) is generally adequate. Up to 15 SCFM (425L/min.) may be required for fuels that may produce high levels of flash or soot, or for hot environments to maintain the scanners internal temperature within specification.

PIPING ARRANGEMENTS (The scanner pictured is not Model 45RM4).

FIGURE 7

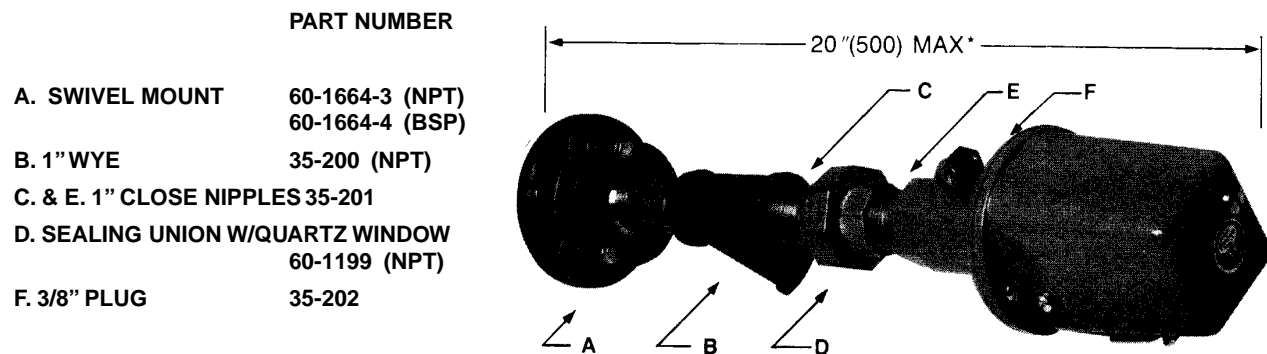

FIGURE 8

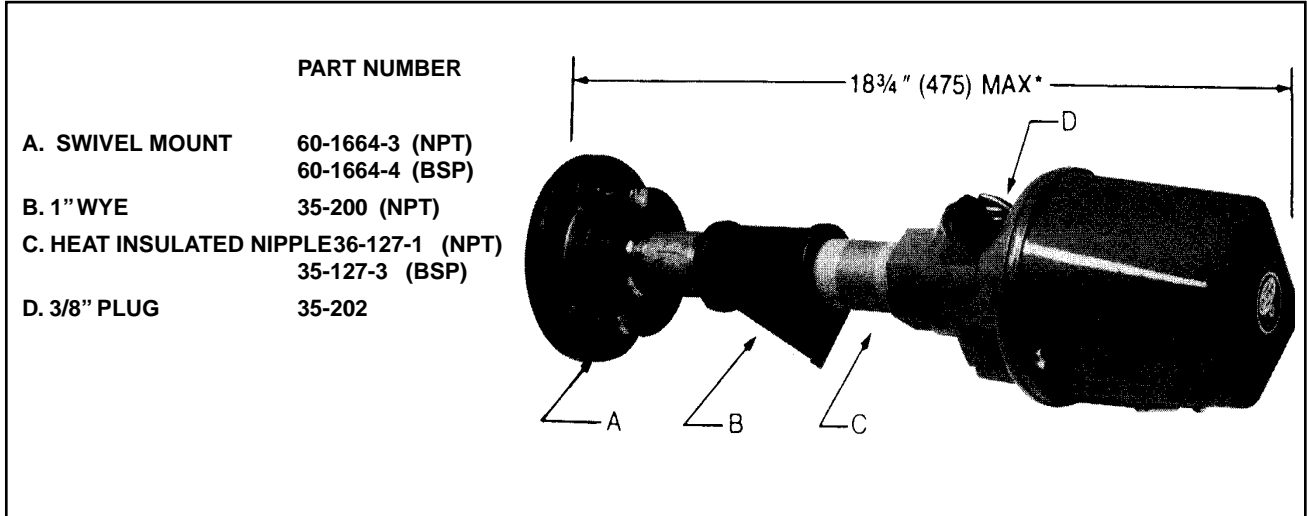
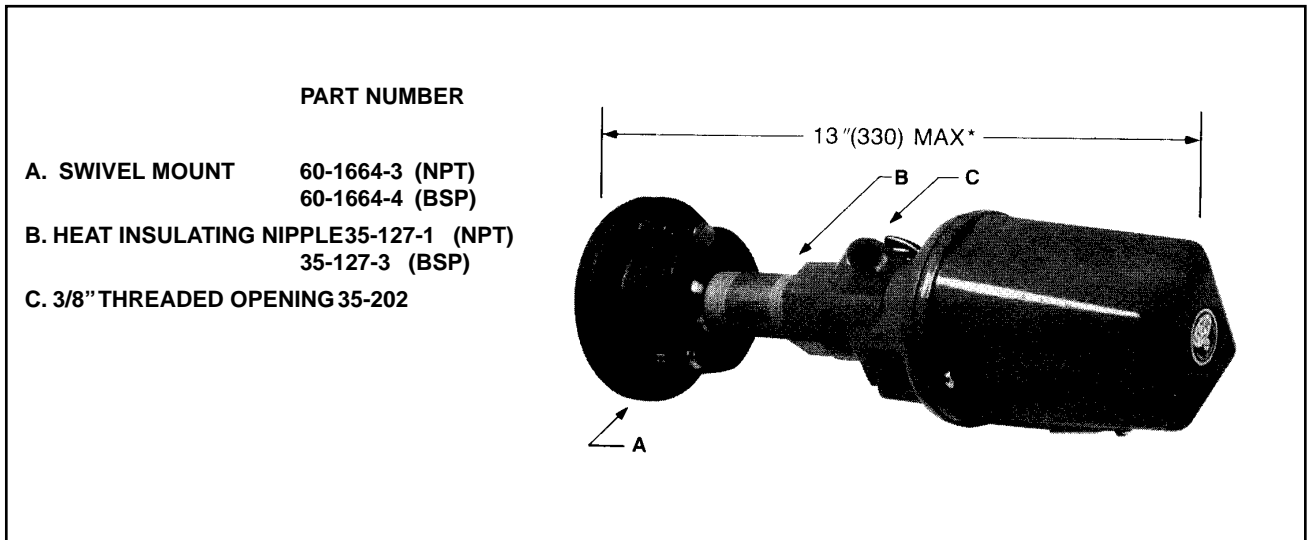

FIGURE 9



ACCESSORIES

FIGURE 10

- A. THROUGH I. ORIFICES .062 TO .5 DIA.
- J. 34-181 ORIFICE RETAINER
- K. 35-127-1 (1" NPT) HEAT INSULATING NIPPLE
35-127-3 (1" BSP) HEAT INSULATING NIPPLE
- L. 46-87 SCANNER LENS
- M. 92-48 SEALING UNION QUARTZ WINDOW
- N. 101-78 DIODE

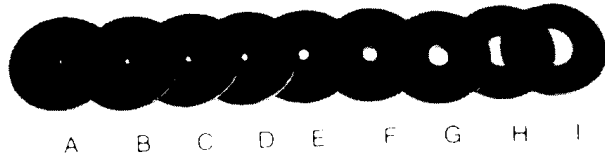

FIGURE #	PART #	DESCRIPTION
8A	53-121-2	ORIFICE .062" DIA.
8B	53-121-3	ORIFICE .078" DIA.
8C	53-121-4	ORIFICE .093" DIA.
8D	53-121-5	ORIFICE .109" DIA.
8E	53-121-6	ORIFICE .125" DIA.
8F	53-121-7	ORIFICE .187" DIA.
8G	53-121-8	ORIFICE .250" DIA.
8H	53-121-9	ORIFICE .375" DIA.
8I	53-121-10	ORIFICE .500" DIA.

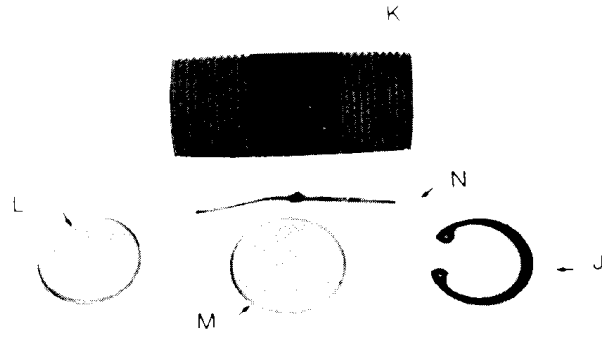

FIGURE 11

- A. 60-1664-3 (1" NPT) SWIVEL MOUNT
60-1664-4 (1" BSP) SWIVEL MOUNT
- B. 60-1199 (NPT) SEALING UNION W/QUARTZ WINDOW
- C. 59-221 SCANNER CABLE

FIGURE #	PART #	DESCRIPTION
5B, 6B	35-200	1" WYE (NPT)
5C, 5E	35-201	1" CLOSE NIPPLE (NPT)
5F, 6D	35-202	3/8" PLUG

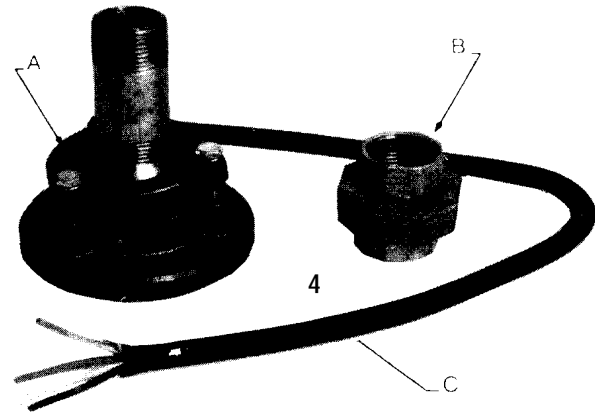
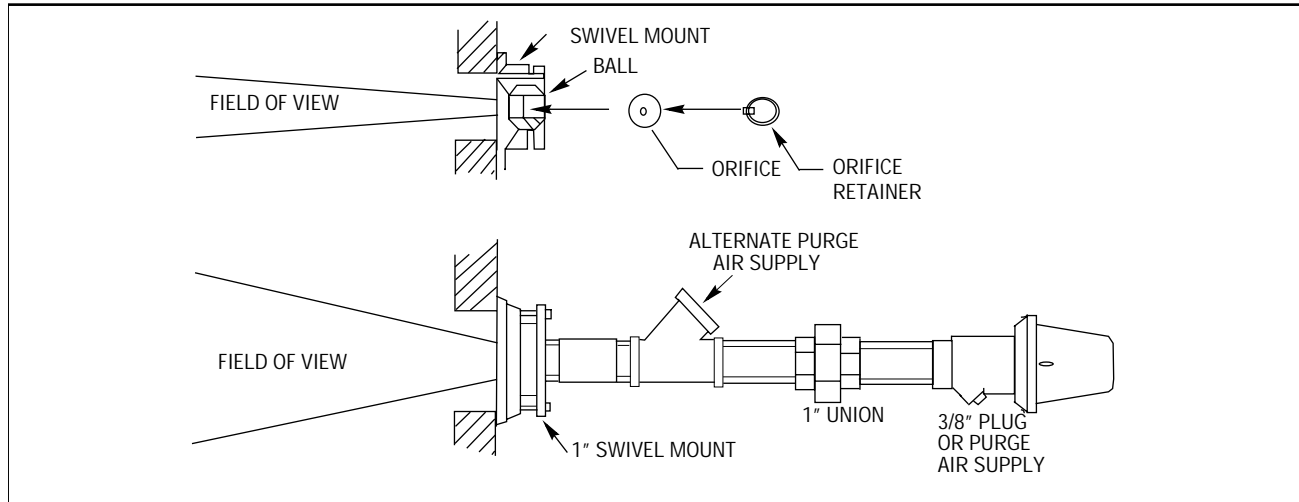

FIGURE 12



USE OF SCANNER ACCESSORIES

Swivel Mount: The scanner swivel mount, P/N 60-1664-3 (NPT) (see Figure 11), is used to adjust the scanner sighting angle after the scanner has been installed. The swivel mount is used as indicated in Figures 7, 8 and 9.

Orifices: The Orifice (Figure 10) is used to restrict field of view (target area), reduce airflow, maintain airblock and increase scanner sensitivity. The orifice is secured within the ball of a swivel mount with an orifice retainer or the orifice can be placed within a 1 inch union (not provided). See Figure 13.

Note: There is an inverse relationship between discrimination and sensitivity.

The scanner should ideally sight a target area of 8 to 25 square inches (50-150cm²) of the flame front. The flame front is a plane within the combustion space separating the region of unburned fuel from the burning fuel. For example, if a 1/2" diameter orifice is placed within the ball of a swivel mount one foot from the scanner lens, and the swivel mount is located on the surface of a 4 foot deep windbox, and if the range of stable flame is 5 feet beyond the windbox, the flame front target area is 19.6 square inches as shown in Figure 13.

FIGURE 13

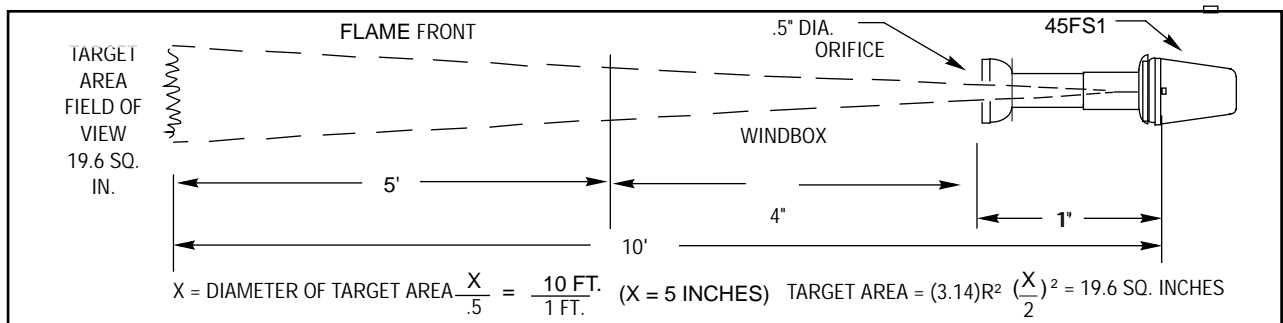

Heat Insulating Nipple: Heat Insulating Nipple, P/N 35-127-1 (1" NPT) (see Figure 10), Item K, is used to prevent heat transfer from the hot sight pipe to the scanner head.

Sealing Union with Quartz Window: The sealing union, P/N 60-1199 (see Figure 11, Item B), is used whenever a coupling or a seal is required for scanner piping. The quartz window blocks furnace pressure, hot gasses and soot from coming in contact with the scanner and contaminating the lens. The size is one inch U.S standard taper pipe thread (Schedule 40, 1 -11 1/2 NPT). When the sealing union is used, a 1 inch "Y" fitting must be used downstream from it for connection of a purge air supply (plug the 3/8" opening). See Figure 7 for piping with the sealing union, Item D.

Electrical Accessories: The diode (101-78) is used whenever a type 45RM4 scanner is operated with a type 45UV5 scanner. Refer to the wiring diagrams for further information. Fireeye scanner cable P/N 59-470 (see Figure 11, Item C) is used for wiring connections between the scanner(s) and the control terminals. Each wire is color coded for connection as follows:

- BLACK is used for the +24VDC terminal.
- RED is used for the self check terminal.
- WHITE is used for the 24VDC common terminal.
- GREEN is flame signal terminal.



ALIGNMENT AND ADJUSTMENTS

Before installing or adjusting scanners, flame scanning objectives and boiler/furnace operation should be thoroughly reviewed.

The following procedures are recommended to ensure optimum flame detection and discrimination. Flame discrimination is the ability to see only one burner or one ignitor with other burners or ignitors operation nearby.



CAUTION: These procedures should be used whenever parts are replaced, when the scanner has been moved, when the flame shape is altered (additional fuels, new burners, burner/register modifications), as well as on new installations.

DESCRIPTION OF FEATURES

The Type 45RM4, Model 1000, 1001 Flame Scanners have the following significant features to improve flame discrimination.

- Gain adjustment potentiometer.
- Selector switch to enable or disable Background Gain Control Function.
- Set of 10 LED indicator lights to show flame signal strength.
- 16 Position frequency selector switch.

Gain Adjustment Potentiometer

The adjustment potentiometer is located under the rear panel of the scanner between the 16 position frequency selector switch and the Background Gain Control selector switch. The gain adjust potentiometer is used to properly amplify both flame on and flame off signals so that maximum discrimination can be attained.

The potentiometer has four (4) active turns and “free-wheels” at either end of travel.

LED Indicator Lights (Flame Strength)

The 45RM4 is equipped with a set of 10 LED's to indicate flame strength. These LED's are helpful in scanner sighting as well as in scanner setup. The LED's are linear, with each LED representing approximately 75 output pulses per second (when viewed at a 25SU3-2000/2100 control). These LED's **DO NOT** correspond to the LED's on the 25SU5-5011 control's optional display board, (P/N 60-2205). The 25SU5 LED's are logarithmic, not linear.

Background Gain Control (BGC) Selection

Background Gain Control (BGC) inversely adjusts the flame signal gain based on flame brightness as sighted by the scanner. (e.g.: flame brightness increases, automatic gain is decreased, and flame signal is decreased).

On some burners, the flame brightness (as sighted by the scanner) increases when the monitored flame goes out due to background refractory, adjacent flames, etc. On these types of burners, the BGC would be selected ON so when the monitored flame goes out, the brightness increases, the gain would be automatically decreased, the strength of the flame signal is decreased, and the flame amplifier would drop out the flame relay. On other burners the opposite is true, and BGC would be selected OFF.

16 Position Frequency Selector Switch

The 45RM4 Scanner is equipped with a 16 position frequency selector switch to aid in the detection and discrimination of the Flame-On and Flame-Off conditions. Depending on the nature of the fuel being burned and the operation of the burner, the modulation frequencies of the flame for these two conditions will vary. The frequency selector switch allows the user to select the appropriate frequency where the greatest discrimination between the Flame-On and Flame-Off condition exists. The selector switch is a rotary switch and has a range for 20 Hz (Position 0) to 170 Hz (Position F). The adjustment from the lower to higher frequencies is linear. See below. The 16 position rotary switch is located under the rear cover of the scanner.

SWITCH POSITION	0	1	2	3	4	5	6	7	8	9	A	B	C	D	E	F
FREQUENCY (Hz)	20	30	40	50	60	70	80	90	100	110	120	130	140	150	160	170

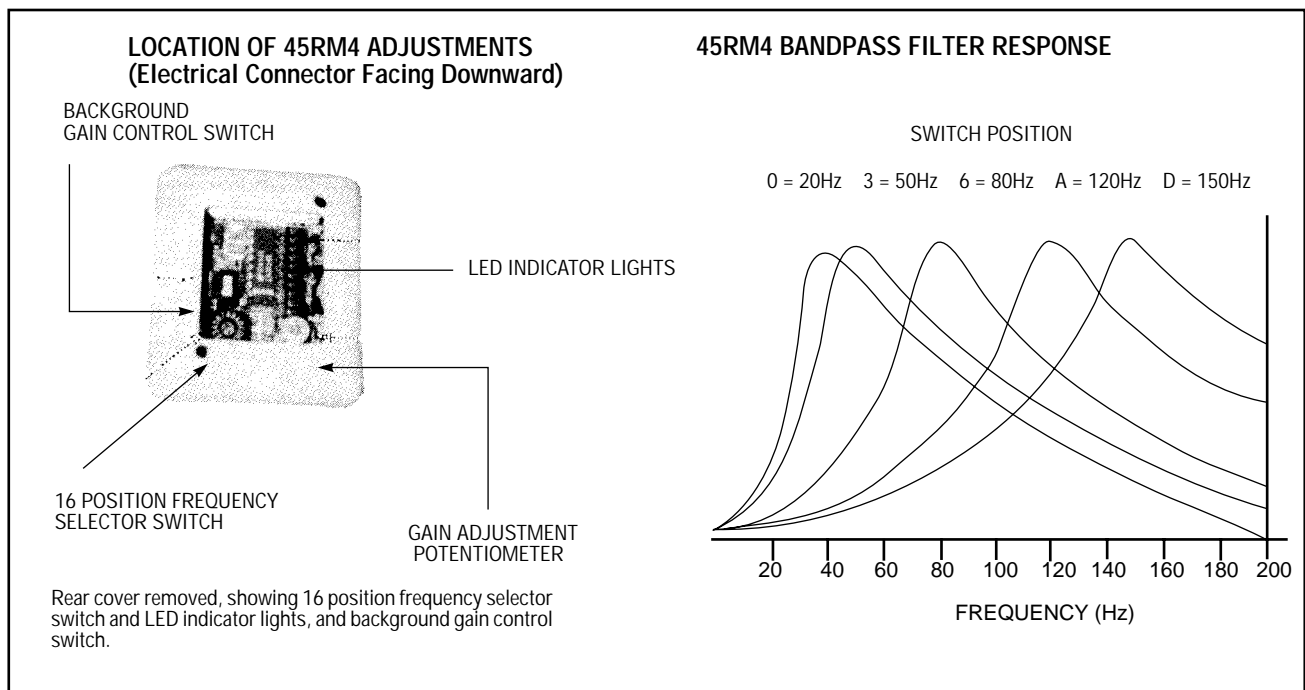

45RM4 SCANNER SET-UP PROCEDURE

Frequency and Gain Selection Procedure

The following steps are offered as a guide in setting up the scanner on a multi-burner application where background sources of infrared radiation may be present. The goal is to set the flame “flicker” frequency and scanner “gain” that yields the greatest flame ON:OFF signal ration. For purposes of illustration only, frequency switch position “6” was selected as the starting point.

1. Select a mid-point HZ (e.g., “6”) and “gain” at maximum.
2. With background burners firing, turn ON target burner.
3. Readjust “gain” to yield 6-8 LED’s at the 45RM4.
4. Adjust scanner alignment to maximize LED’s.
5. Sweep through all 16 HZ positions, recording LED’s at each step.
6. Turn target burner OFF.
7. Sweep all 16 HZ positions, recording LED’s at each step.
8. Select HZ with the greatest flame ON:OFF ratio.



FREQUENCY SETTING	1	2	3	4	5	6	7	8	9	10	A	B	C	D	E	F
RATIO OBSERVED	1.5	1.6	1.7	1.9	2.0	2.0	2.1	2.2	2.3	2.4	2.6	2.9	3.0	2.8	2.5	2.0

In the above example, frequency position “C” would be selected, as it yielded the greatest flame LED ON:OFF ratio (3.0: 1). If two or more frequency positions yield the same ratio, select the higher frequency position. If possible, for most reliable operation, avoid the lowest frequency positions (0, 1, 2).

Background Gain Control (BGC) Switch Position Selection Procedure

1. Place BGC switch OFF (toward cable connector).
2. With target and background burners firing at high input, record flame LED's at the 45RM4.
3. Turn target burner OFF, record flame LED's and determine flame ON:OFF ratio.
4. Place BGC switch ON (away from cable connector).
5. Turn target burner ON, record flame LED's.
6. Turn target burner OFF, record flame LED's and determine flame ON:OFF ratio.
7. Select the BGC switch position that yielded the greater flame ON:OFF LED ratio, and /or yielded the greater LED stability.

AMPLIFIER ADJUSTMENT

Analog Controls (e.g. 25SU5-5011, 25SU3-5166)

The analog controls have fixed (non-adjustable) flame relay pull-in and drop-out thresholds. The purpose of the procedure is to “tune-out” unwanted (background) flame signal either by reducing the 45RM4 output via its “gain” potentiometer, and/or via the analog control’s “sensitivity” adjustment.

Once the 45RM4 flame scanner has been properly set up, turn the burner flame OFF and adjust the sensitivity adjustment on the flame amplifier to its maximum gain adjustment. Then slowly decrease the sensitivity adjustment on the flame amplifier until the flame relay de-energizes. The 45RM4 flame scanner and amplifier should now be set up for proper operation. See “CAUTION” below.

Digital Controls (e.g. 25SU3-2000, 25SU3-2100)

The digital controls have adjustable flame relay pull-in and drop-out thresholds, in terms of the scanner output pulses viewed on the digital control’s display. Assume, for example, the 45RM4 scanner generated 600 pulses per second (pps) when the target flame was ON, and 200 pps when the target flame was OFF (due to background flames). You would program the digital control’s “Flame Relay ON Threshold” to some value lower than 600 pps, and program the “Flame Relay OFF Threshold” to some value higher than 200 pps. Alternately, you may reduce the scanner’s “gain” setting to yield 300 pps (ON) and 0 pps (OFF). Verify the actual pulse counts (flame ON and flame OFF) at all firing conditions to confirm that the programmed thresholds provide reliable detection and discrimination at all times. See “CAUTION” below.



CAUTION: On all applications the scanner and amplifier must be tested by starting and stopping the burner several times to ensure proper operation. (e.g.: The flame relay must reliably drop out for all flame out conditions.) This testing should be done with various adjacent burners on and off and at various load levels. This is a requirement for proper operation.



SCANNER WIRING

All wiring to the scanner should be rated at 600 volts and 90C. For runs less than 1000 feet, the use of Fireeye Scanner Cable (4-18 AWG, 2-22AWG, overall shield), P/N 59-470 is recommended. Consult the factory for runs in excess of 1000 feet.

The scanner cable should be routed to the quick disconnect using acceptable wiring practices (e.g. use of wiring troughs—keep scanner cable away from wiring for high inductive loads, etc.)

QUICK DISCONNECT KIT P/N 129-127-6 (Ordered Separately)

For ease of installation and removal, a quick disconnect is used with the 45RM4 scanners. The male connector is factory mounted on the scanner. The female cable connector kit, P/N 129-127-6, is ordered separately. This assembly procedure applies to Fireeye six-conductor cable (P/N 59-470), eight-conductor cables (P/N 59-471), and obsolete four-conductor cable (P/N 59-221).

Fireeye recommends that the scanner cable be installed in flexible metallic conduit at the burner front. Referring to Figure 15, locate the end of the cable where the red wire is *clockwise* with respect to the white wire. For ease of assembly, this end should be connected to the scanner quick disconnect.

ASSEMBLY (Refer to figure 16)

1. Pull the Fireeye scanner cable through flexible (e.g. "Seal-tight") conduit at the burner front.
2. Test the rubber cable seal for proper fit, (part of cable seal kit). Depending on the cable used, it may be necessary to remove inner ring(s) to provide a snug fit. Set aside until step 10.
3. Strip the outer cable jacket 2 1/2 inch (64 mm).
4. Trim insulated conductors to 1 3/8 inch (35 mm), leave the shield drain wire 2 1/2."
5. Strip individual conductor insulation 5/16 inch (8 mm).
6. Install the PG16 to 1/2 inch flexible conduit adapter onto the cable.
7. Install the PG11 / PG16 adapter onto the cable. (With flexible conduit, the PG11 / PG16 adapter *replaces* the nut provided with the cable seal kit.)
8. Install the first of two flat washers, (part of cable seal kit), onto the cable.
9. Fold the shield drain wire back along the cable outer jacket.
10. Slide the rubber seal and second flat washer, (part of cable seal kit), onto the cable *over* the shield drain wire. Leave the rubber seal on top of the *end* of the drain wire until step 17.
11. Crimp the female contacts onto the individual conductors, (or solder, using the *least* amount of solder).
12. Install the connector hood on the cable, making sure the hood nut is removed.
13. Install the contacts into the female insert in the appropriate order. When properly installed, the contacts will "click" into the insert. Verify by pulling slightly on each wire. Install the smaller female contacts on the smaller 22 AWG scanner wires (blue, yellow) if used.
14. Place the threaded hood nut over the female insert.
15. Slide the connector hood over the female insert, aligning the hood locating "key" with the wide groove on the female insert.
16. Tighten the threaded hood nut.
17. Slide the second flat washer and the rubber seal into the connector hood. Push into place until firmly seated.
18. Wrap the shield drain wire around the cable jacket *one* turn only, (between the rubber seal and the first washer, wrapped *clockwise* as viewed from the conduit adapter), and trim any excess length.
19. Slide the first flat washer into the connector hood, on top of the drain wire.

20. Install the PG11 / PG16 adapter and tighten firmly to properly compress the rubber seal. This also compresses the first washer against the drain wire, electrically connecting the shield to the connector hood.

21. Install the PG16 to 1/2 inch flexible conduit adapter.

Before applying power, perform a continuity check on each conductor to confirm proper assembly. Confirm that you have continuity between the cable shield (at the amplifier end of the cable) and the quick disconnect hood (metal housing).

FIGURE 14.

QUICK DISCONNECT TERMINALS

	WIRE COLOR	PIN	FUNCTION
59-470 LEADS	GREEN	→ 3	FLAME SIGNAL
	RED	→ 2	SHUTTER
	WHITE	→ \perp	COMMON
	BLACK	→ 1	+24VDC
	BLUE	→ 5	(UNUSED)
	YELLOW	→ 7	(UNUSED)

FIGURE 15.

FOR EASE OF CONNECTOR ASSEMBLY, INSTALL ON END SHOWN

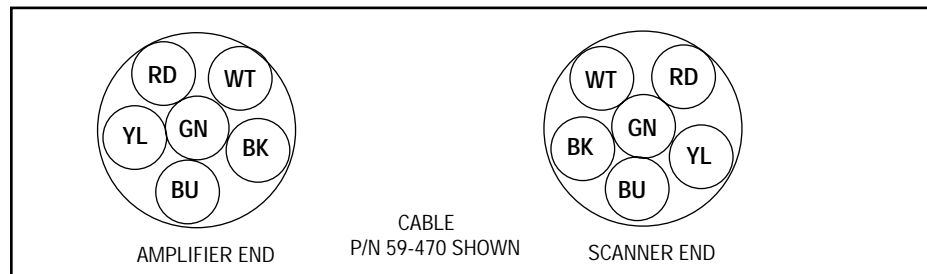
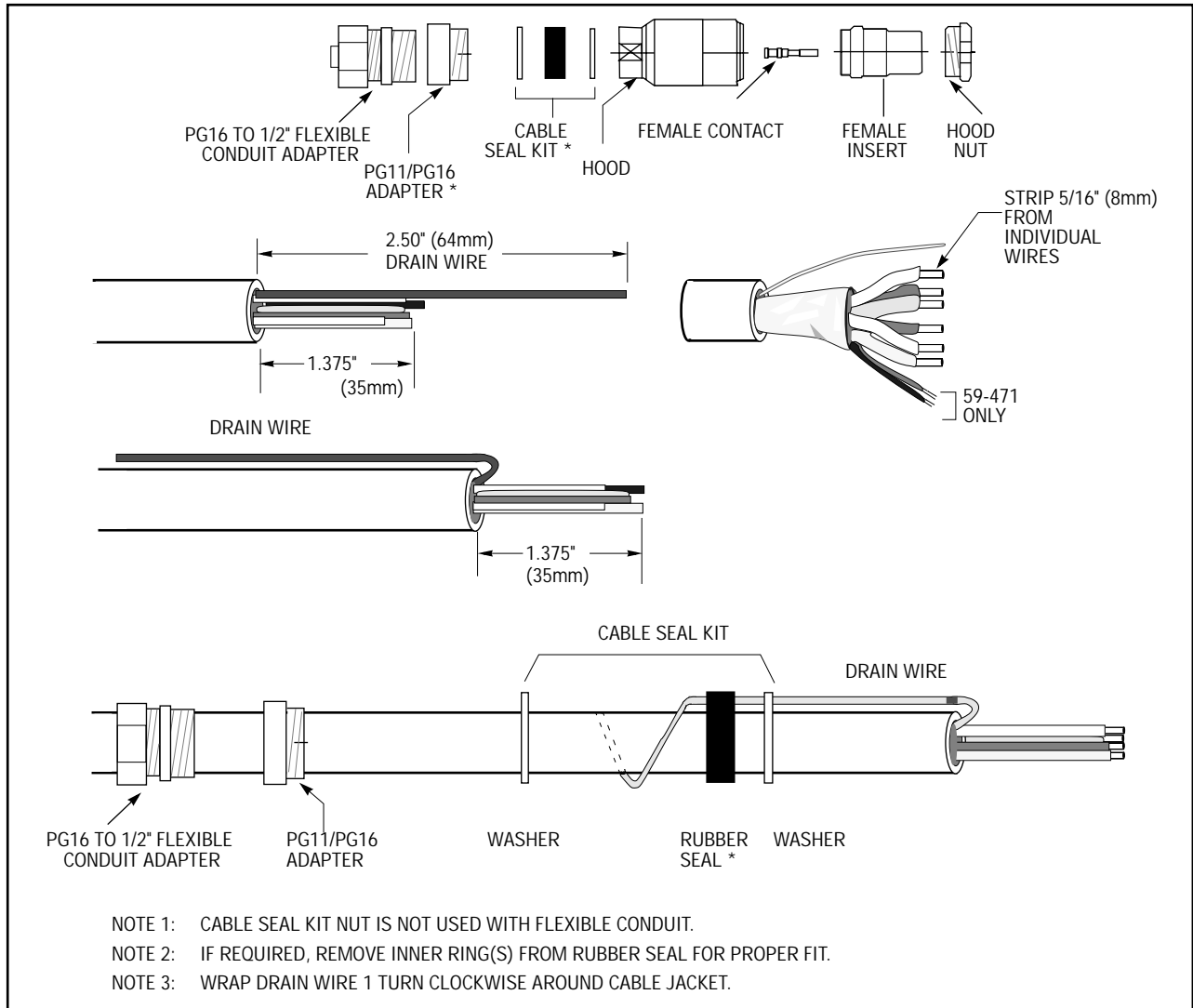

FIGURE 16.



GROUNDING AND SHIELDING TECHNIQUES

FOR USE ON SCANNERS OR SCANNER CABLE LOCATED WITHIN 12" OF A HIGH ENERGY OR HIGH VOLTAGE SOURCE.

1. The scanner and scanner cable (preferably within flexible conduit) **MUST** be located at least one foot (1') from the ignition source.
2. Run a ground wire from the ignition transformer chassis to the ignitor assembly.
3. Replace all frayed, cracked, or dirty (oily) ignition wire. Ignition wire must be in good working condition.
4. Electrically isolate the scanner from the burner using a heat insulating nipple provided with the scanner, (Part # 35-127-1 or 35-127-3).

NOTE: If purge air is required, **PURGE AIR** must be electrically isolated from the scanner (e.g. isolated short rubber hose).

FIGURE 17

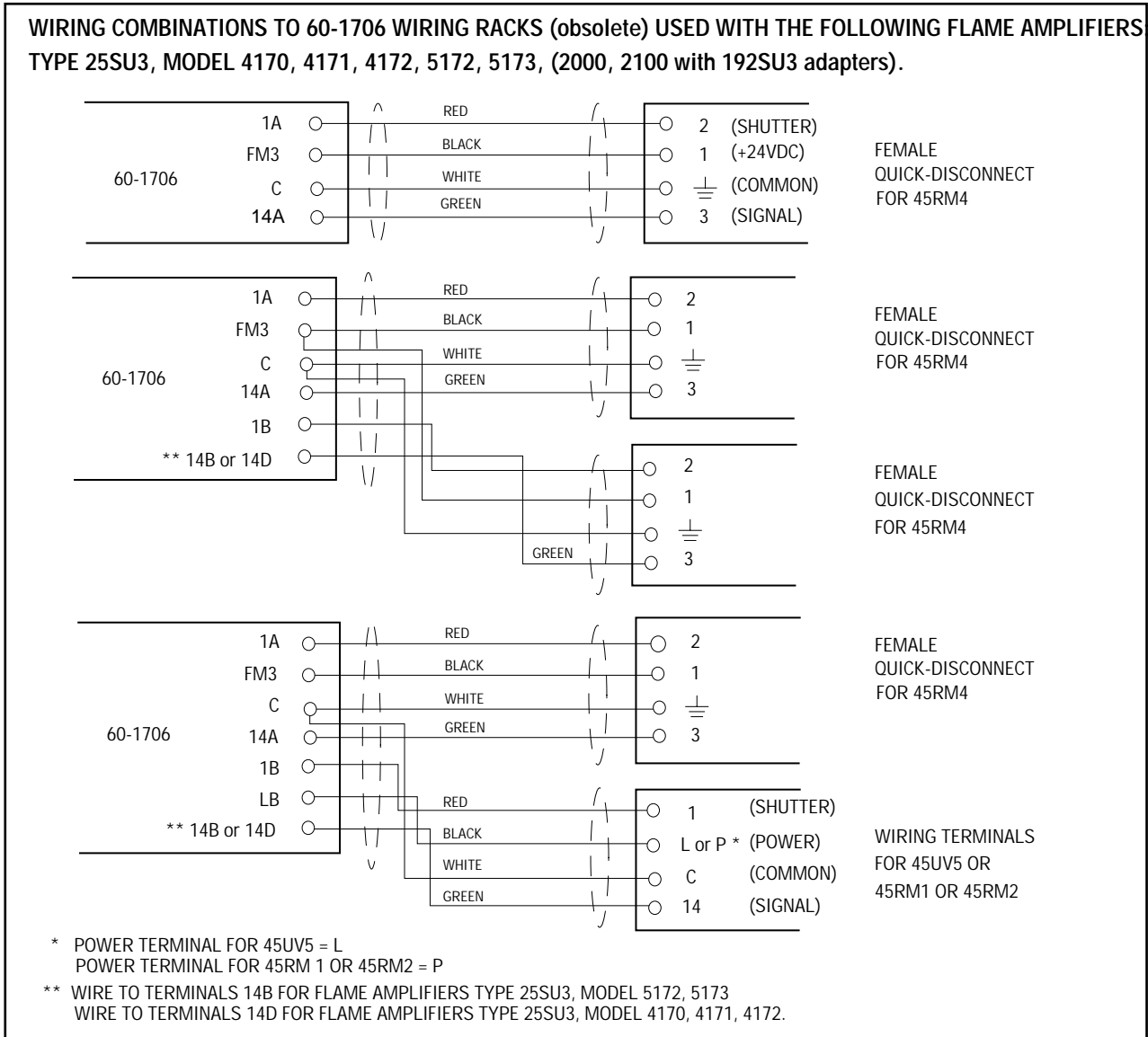

Notes for 45RM1, 45RM2, 45UV5 scanners only:

1. Connect the scanner cable's shield to terminal C at the control end only; the shield at the scanner end should be left disconnected.
 - Strip six inches of insulation from scanner end of cable.
 - Cut off the six inches of cable shield that is visible.
 - Tape the cable's insulation where it terminates so the cable shield is not visible.
2. Flame amplifier rack, P/N 60-1706, has a blocking diode between terminals 14A and 14D.

FIGURE 18 WIRING COMBINATIONS TO 60-2206-1 AND 60-2206-2 WIRING BASE USED WITH THE FOLLOWING FLAME AMPLIFIERS: TYPE 25SU5, MODEL 5011 (60-2206-1) TYPE 25SU3, MODEL 5166 (60-2206-2)

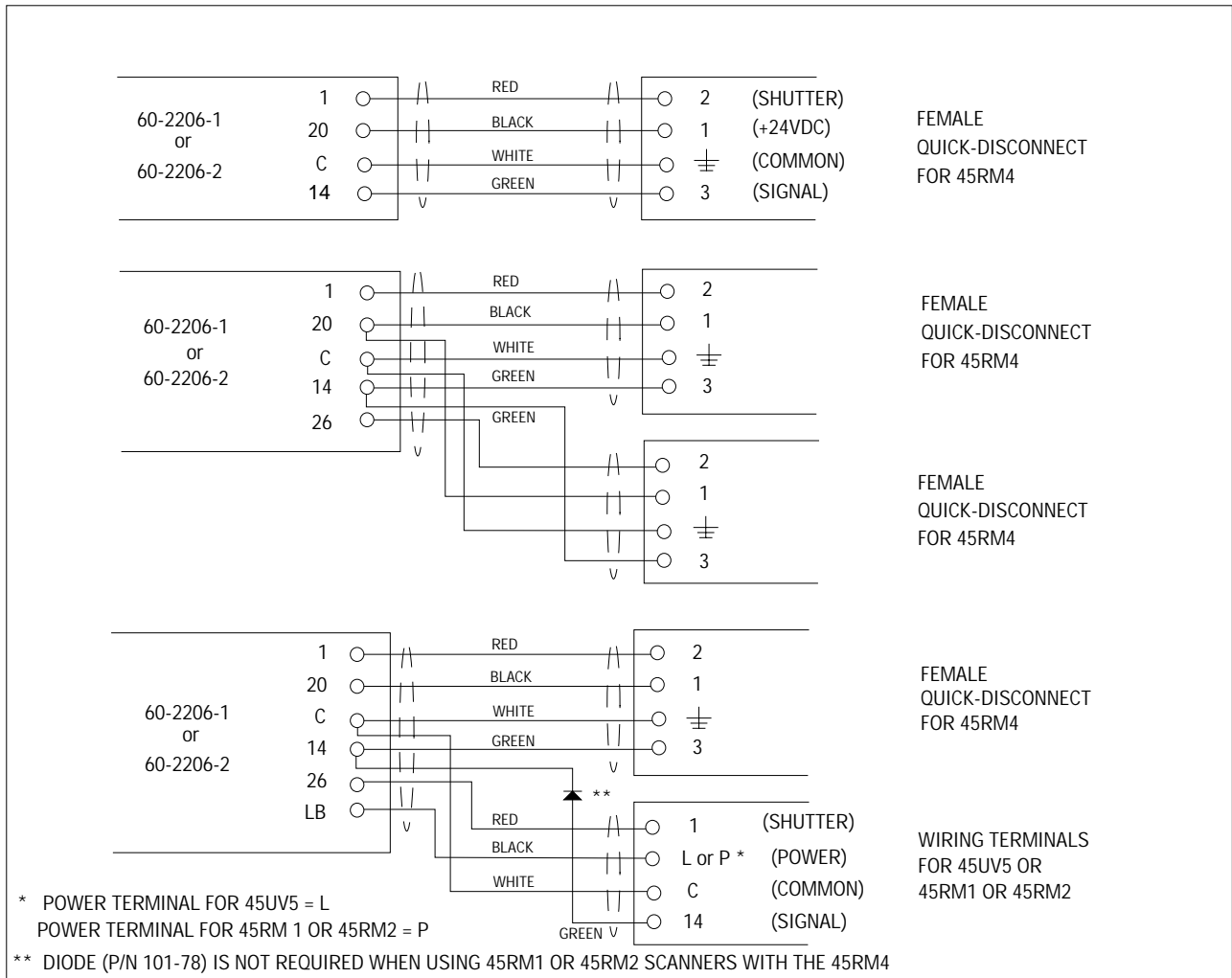

Notes for 45RM1, 45RM2, 45UV5 scanners only.

NOTE: Connect the scanner cable's shield to terminal C at the control end only; the shield at the scanner end should be left disconnected.

1. Strip six inches of insulation from scanner end of cable.
2. Cut off the six inches of cable shield that is visible.
3. Tape the cable's insulation where it terminates so the cable shield is not visible.

FIGURE 19 WIRING COMBINATIONS TO 60-2478 CONNECTOR, USED WITH CARD RACK FOR 25SU3-2000/2100 FLAME AMPLIFIERS

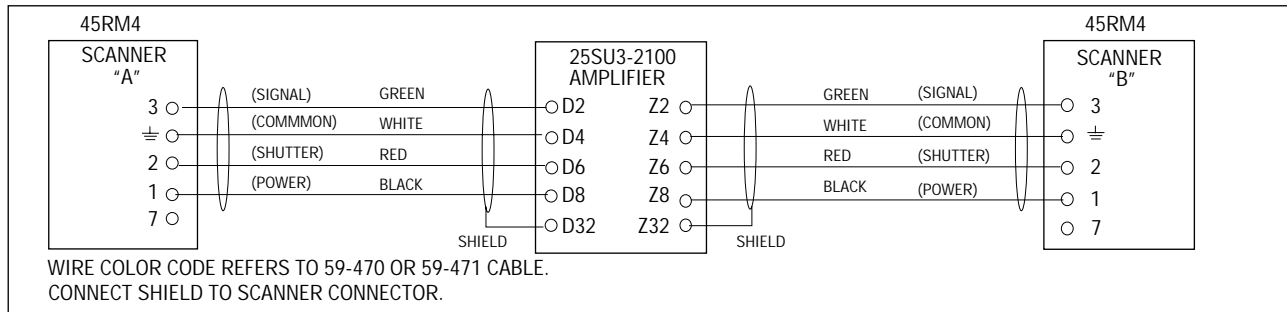

MAINTENANCE

Humidity Effects: It is considered good practice to minimize any possible adverse effects of high humidity by keeping electronic equipment continuously powered, even during periods when it is not in use.

Scanner: If continuous air purging of the scanner sight pipe is not completely effective in preventing viewing window contamination, a schedule should be set up for periodically cleaning the window. Always use a soft clean, (non-oily) cloth to wipe the window. For maximum assurance that oily films will be removed, wash first using a cloth dampened, (not dripping) with a concentrated detergent solution.

Use original Fireye repair parts to maintain optimum operation



CAUTION: DISCONNECT OR SHUT OFF ELECTRIC POWER WHEN WORKING ON SCANNER.

FIGURE 20

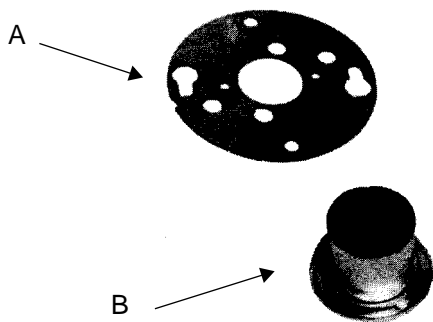

- A. 29-248 FLANGE GASKET
- B. 61-2275-3 GLASS LENS ASSEMBLY.

Original equipment factory replacement parts are available at various sub-assembly levels. For example, in Figure 20, item B, the Glass Lens Assembly (61-2275-3) contains three parts which can be purchased as a unit, or separately.

TROUBLESHOOTING

The following steps should be performed if flame is not detected

1. Check scanner wiring for breaks, loose, or improper connections.



WARNING: PROTECTIVE FILTERED LENSES SHOULD BE WORN WHEN VIEWING FLAME. INFRARED AND ULTRAVIOLET ENERGY CAN BE DAMAGING TO THE EYES.

2. Look down the sight pipe.
 - a. Scanner should have an unrestricted view for all firing conditions.
 - b. The flame's primary combustion zone (first 1/3 of flame) should be within the scanner's field of view for all firing loads.
3. Clean the scanner lens with a glass detergent or glass cleaning agents which contains no abrasives. After cleaning, remove all cleaning films with a soft lint-free cloth.
4. Check to see if the self-check circuits are operating. There should be 16-24VDC (cycling) between self-check and common terminals (refer to amplifier bulletin).
5. Measure voltage across scanner terminals:
 - a. Between signal and common terminals there should be 12 VAC pulses of 40 microseconds.
 - b. Between power and common terminals there should be +24 VDC.
6. Scanner operation can be checked by aiming it at a fluorescent, or high intensity light and waving your hand in front of the scanner's lens. The meter of the associated control should indicate flame.
7. Check to see that an external selector switch is connected to the associated Fireye control's sensitivity (threshold) select terminals.
8. Reposition scanner so it is properly aligned for best flame signal.



NOTICE

When Fireeye products are combined with equipment manufactured by others and/or integrated into systems designed or manufactured by others, the Fireeye warranty, as stated in its General Terms and Conditions of Sale, pertains only to the Fireeye products and not to any other equipment or to the combined system or its overall performance.

WARRANTIES

FIREYE guarantees for *one year from the date of installation or 18 months from date of manufacture* of its products to replace, or, at its option, to repair any product or part thereof (except lamps, electronic tubes and photocells) which is found defective in material or workmanship or which otherwise fails to conform to the description of the product on the face of its sales order. **THE FOREGOING IS IN LIEU OF ALL OTHER WARRANTIES AND FIREYE MAKES NO WARRANTY OF MERCHANTABILITY OR ANY OTHER WARRANTY, EXPRESS OR IMPLIED.** Except as specifically stated in these general terms and conditions of sale, remedies with respect to any product or part number manufactured or sold by Fireeye shall be limited exclusively to the right to replacement or repair as above provided. In no event shall Fireeye be liable for consequential or special damages of any nature that may arise in connection with such product or part.



® FIREYE
3 Manchester Road
Derry, New Hampshire 03038 USA
<http://www.fireeye.com>

CU-31
JULY 2000
Supersedes March 1999